

Xenon-Topaz 2.0/50

The Xenon-Topaz 2.0/50 is part of the robust C-Mount lens series for 1.1" sensor up to 12 megapixel resolution.

Optimized for 10 m to 30 m working distance and equipped with 400 nm - 1000 nm broadband AR-coating this lens is the ideal choice to be used in measurement systems in harsh environmental, as traffic surveillance or robot vision.

A version with motorized p-iris is also available. Lenses with 6.5 mm, 25 mm, 30 mm and 38 mm focal length complete the Xenon-Topaz series.

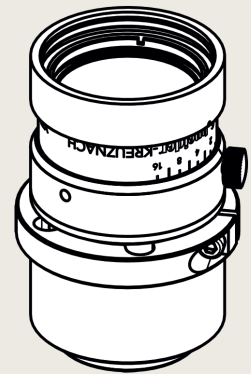

Xenon-Topaz 2.0/50

Key features

- High-resolution optics for up to 12 megapixel 1.1" sensors
- Optimized for 10 m to 30 m working distance
- Broadband coating (400 - 1000 nm)
- Vibration insensitivity for stable imaging performance
- Version with motorized p-iris available

Applications

- Traffic
- High-End Surveillance
- Robot Vision
- 3D measurement

Name	Xenon-Topaz 2.0/50
Type	-0901 -1901
Focal Length [mm]	50
Magnification	-0.1
Image circle [mm]	17.6
Resolution [μm]	3.65
F/# range	2 ... 11
NA	0.25
Interface	C-Mount
Working distance [mm]	∞ - 511
AoV [°]	20
Focus control	manual
Transmission [nm]	400 - 1000
Filter thread [mm]	M30,5 x 0,5
Dimensions L x D [mm]	56.9 x 50.0

Name	Xenon-Topaz 2.0/50
Weight [g]	204
Storage temperature [°C]	-25 ... +70
f'_{eff} [mm]	49.69
S_F [mm]	-12.62
S'_F [mm]	23.52
HH' [mm]	-20.79
β'_P	1.124
S_{EP} [mm]	41.58
S'_{AP} [mm]	-32.64
Σd [mm]	42.45
ID	1079220
ID Motorized p-iris	1084649

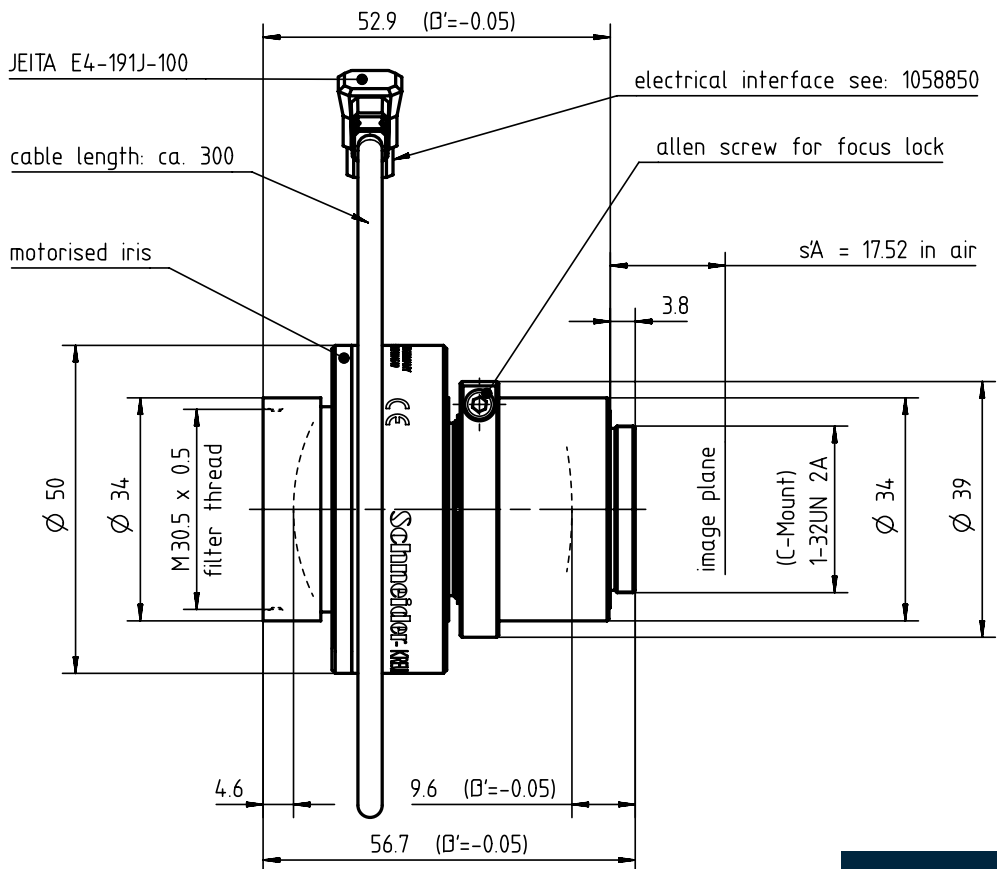
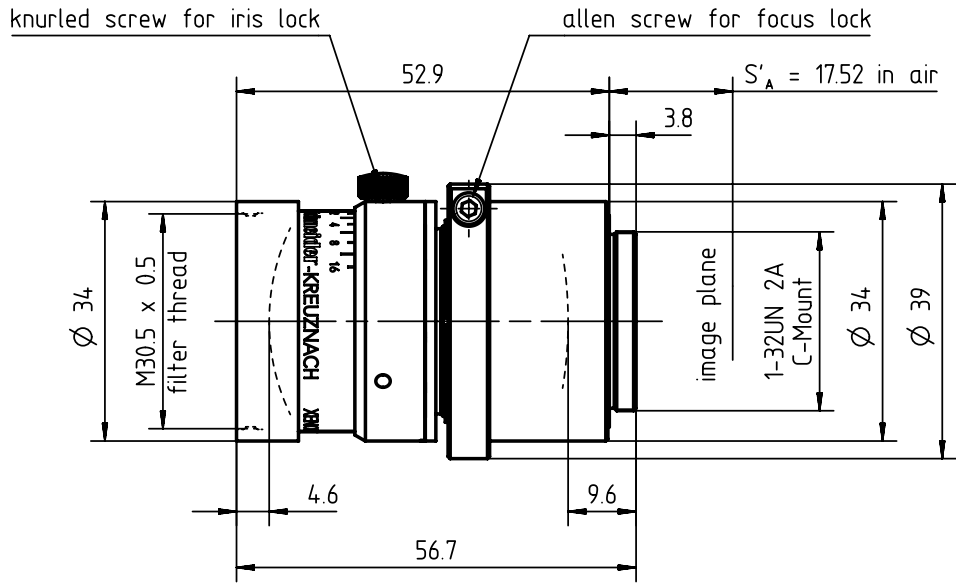

Motorized p-iris

Distortion vs. Image Height

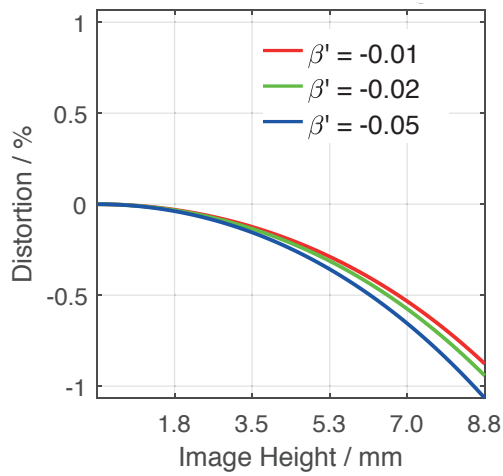

Transmittance vs. Wavelength

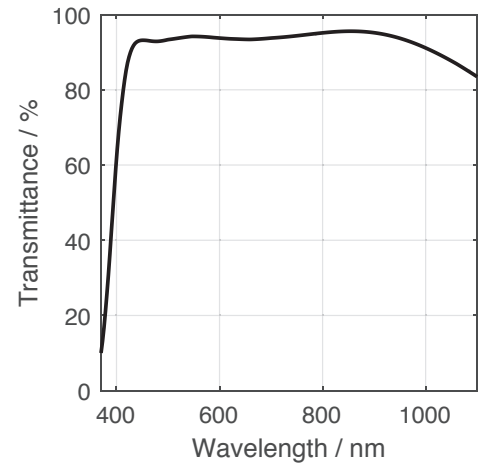

Relative Illumination vs. Image Height

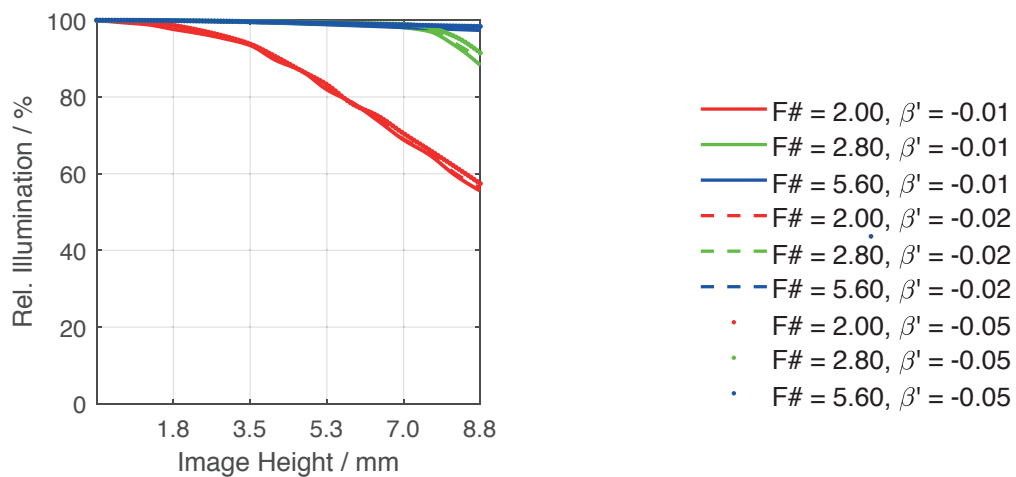

Spectrum Name	VIS					
Wavelengths [nm]	425	475	525	575	625	675
Weights	8	16	23	22	19	13

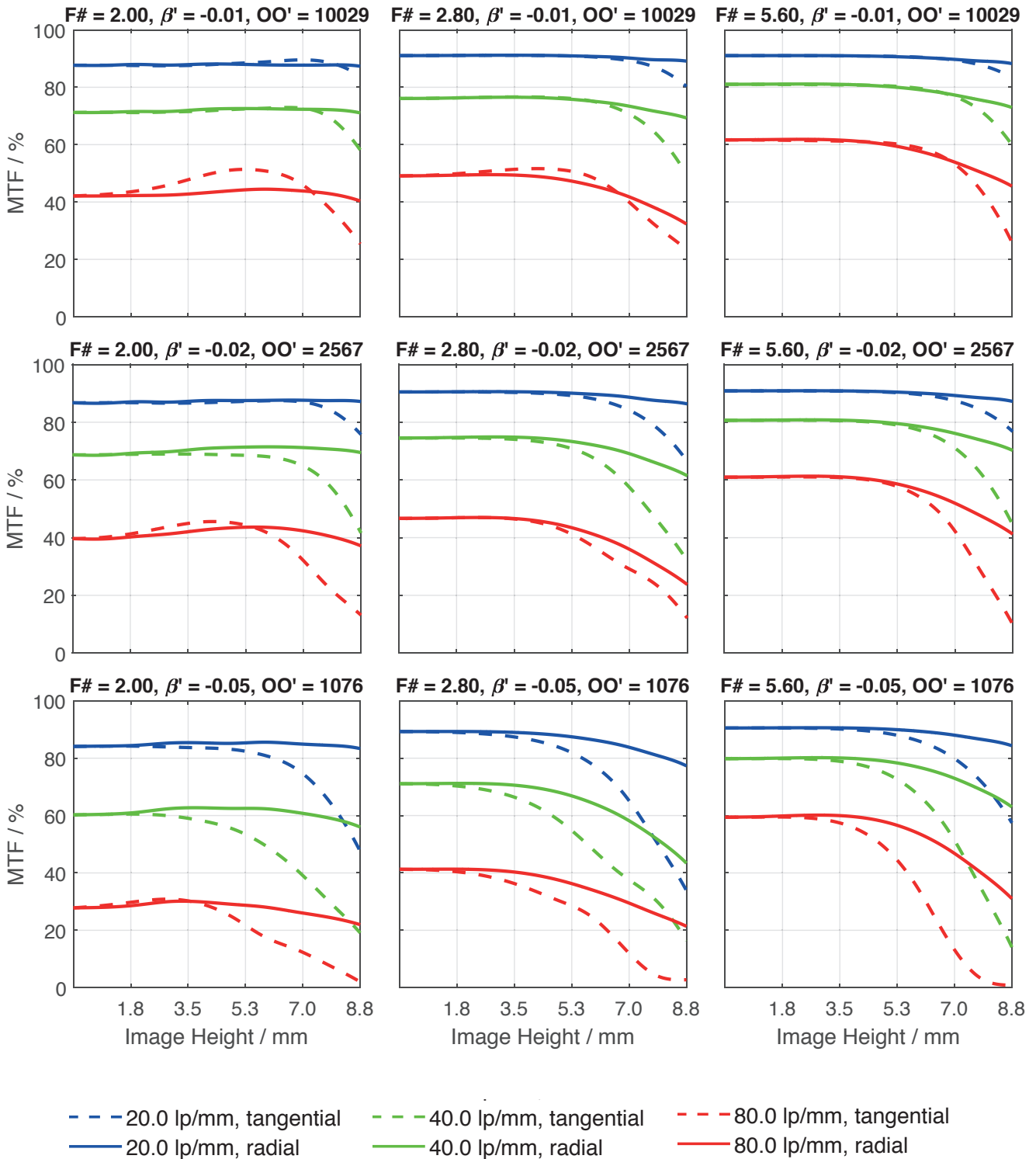

Accessories	Mount	Length	ID
Adapter	CS-Mount Adapter	5 mm	25081
	C-Mount / M42 x 1 Adapter	-	1075817
Ext. Tube	C-Mount	5 mm	39316
	C-Mount	8 mm	39315
	C-Mount	10 mm	39312

Get more information

Contact our local offices



Headquarter Germany

Jos. Schneider Optische Werke GmbH
Ringstraße 132
55543 Bad Kreuznach
☎ +49 671 601 205
✉ cs@schneiderkreuznach.com
www.schneiderkreuznach.com

Offices Worldwide

China

☎ +86 755 8832 1170
✉ shawn.liu@schneider-asiapacific.com

North America

☎ +1 800 645 7239 (East Coast)
☎ +1 800 228 1254 (West Coast)
✉ info@schneideroptics.com

Singapore

☎ +65 9488 0062
✉ thongv@schneiderkreuznach.com