

Compact 35 mm focal length C-Mount lens for megapixel 2/3" sensors with the 400 nm - 1000 nm broadband AR-coating. Useable from VIS to NIR and featured low chromatic apparition, this lens is ideal for challenging mapping solutions.

The high imaging performance over the entire field, makes this lens suitable automated inspection systems when a large field of view and near working distance is needed. As ruggedized version with special locking of the mechanics to compensate industrial environment, such as machine vibration or for instants, is offered. Another option is the High-end 3D version characterized by extra secured optics to assure that the set optical parameters remain in place, needed when the lens get mounted on a robot. And a motorized p-iris version for use in automated inspection systems is available as well. More available focal length are 4.8 mm, 6 mm, 8 mm, 12 mm, 17 mm and 23 mm.



Xenoplan 1.9/35

Key features

- For 2/3" sensors up to 5 megapixel
- 400 nm to 1000 nm Broadband AR coating
- Ruggedized version available
- High-end 3D version available
- Motorized p-iris available

Applications

- Automated Inspection
- Quality control
- Robot vision
- Food and Beverage check
- Mapping

Name	Xenoplan 1.9/35
Type	-0901 -0931 -1908
Focal Length [mm]	35
Magnification	-0.1
Image circle [mm]	11
Resolution [μm]	3.65
F/# range	1.9 ... 16
NA	0.26
Interface	C-Mount
Working distance [mm]	∞ - 358
AoV [°]	17
Focus control	manual
Transmission [nm]	400 - 1000
Filter thread [mm]	M30.5 x 0.5
Dimensions L x D [mm]	38.5 x 34.0

Name	Xenoplan 1.9/35
Weight [g]	92
Storage temperature [°C]	-25 ... +70
f'_{eff} [mm]	34.92
S_F [mm]	-6.69
S'_F [mm]	17.03
HH' [mm]	-13.62
β'_P	0.909
S_{EP} [mm]	31.73
S'_{AP} [mm]	-14.72
Σd [mm]	32.51
ID	1001960
ID Ruggedized	1062872
ID Motorized p-iris	1061453

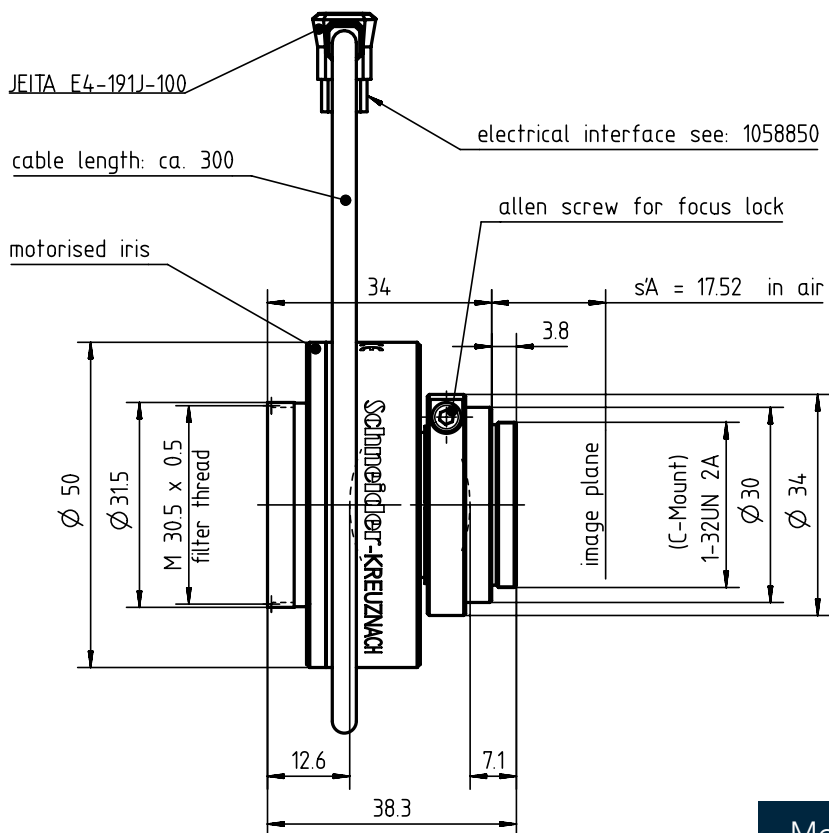
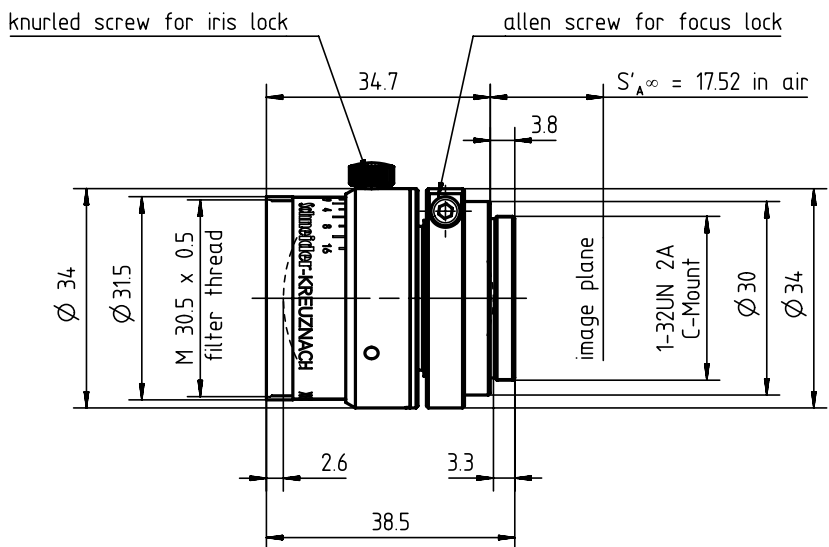

Motorized p-iris

Distortion vs. Image Height

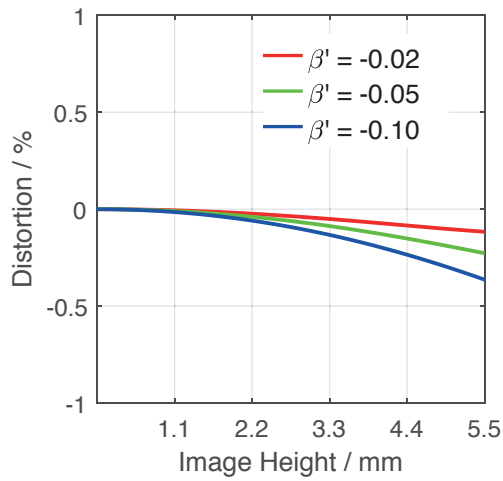

Transmittance vs. Wavelength

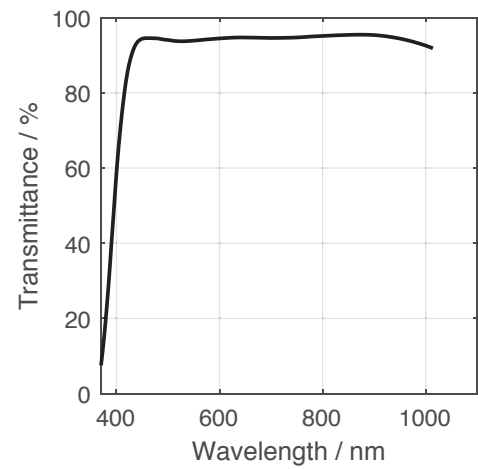

Relative Illumination vs. Image Height

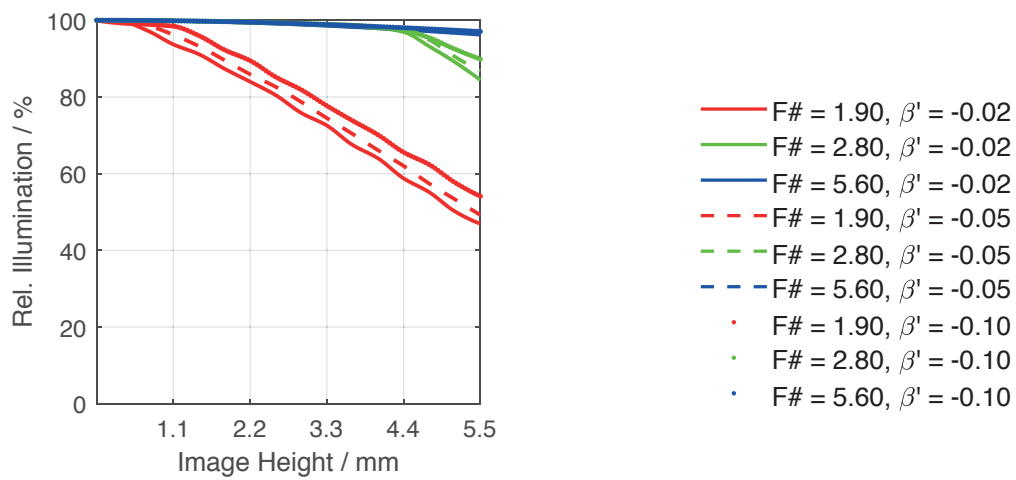

Spectrum Name	VIS					
Wavelengths [nm]	425	475	525	575	625	675
Weights	8	16	23	22	19	13

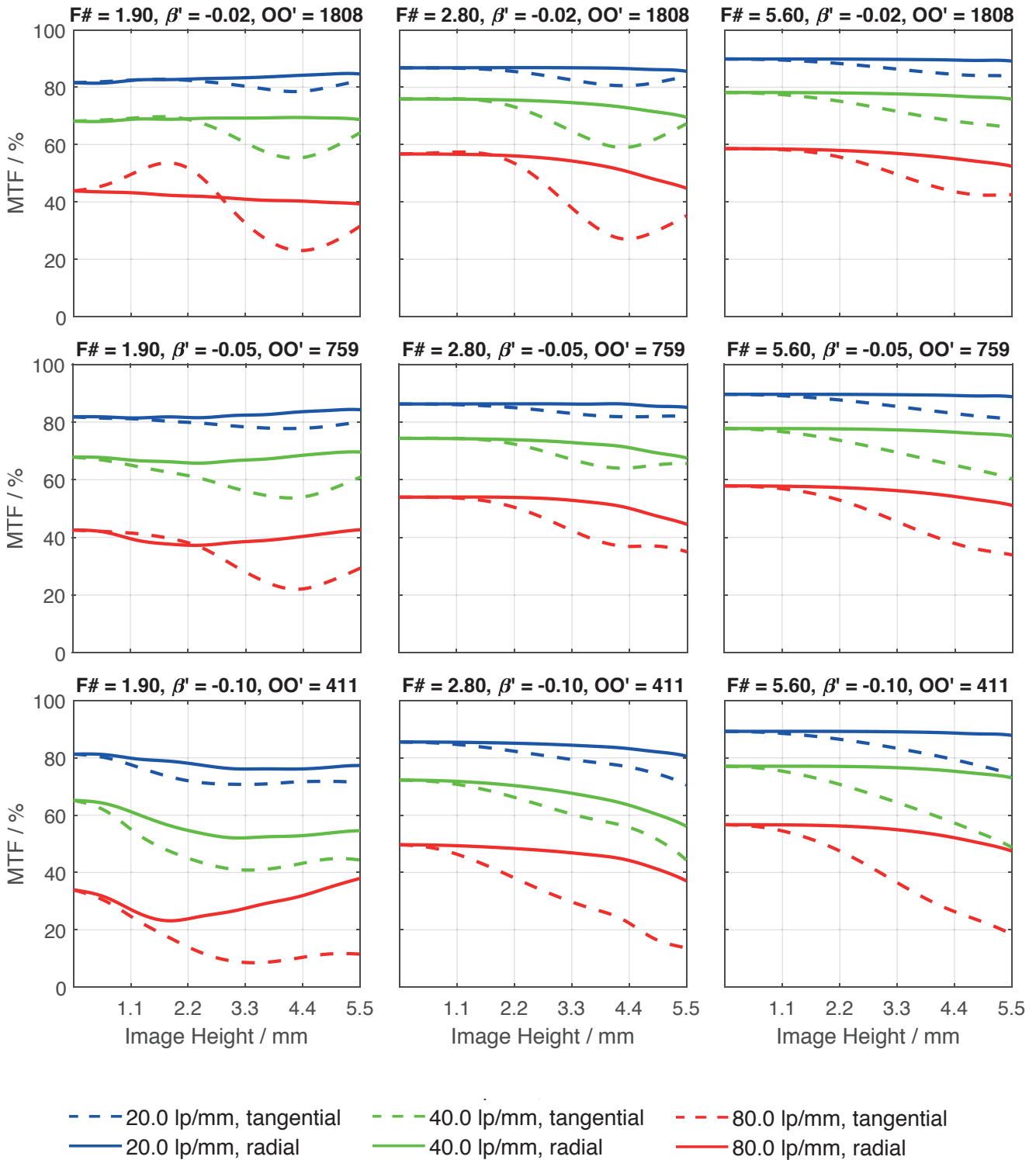

Accessories	Mount	Length	ID
Adapter	CS-Mount Adapter	5 mm	25081
	C-Mount / M42 x 1 Adapter	-	1075817
Ext. Tube	C-Mount	5 mm	39316
	C-Mount	8 mm	39315
	C-Mount	10 mm	39312

Get more information

Contact our local offices



Headquarter Germany

Jos. Schneider Optische Werke GmbH
Ringstraße 132
55543 Bad Kreuznach
☎ +49 671 601 205
✉ cs@schneiderkreuznach.com
www.schneiderkreuznach.com

Offices Worldwide

China

☎ +86 755 8832 1170
✉ shawn.liu@schneider-asiapacific.com

North America

☎ +1 800 645 7239 (East Coast)
☎ +1 800 228 1254 (West Coast)
✉ info@schneideroptics.com

Singapore

☎ +65 9488 0062
✉ thongv@schneiderkreuznach.com