

<b>SPEC. INFO</b>	<b>C 6 Z 1 2 1 8 M 3 - 5 Z S P E C .</b>	31225-S501-000Z-B13
		NOV 29. ' 04

- 1. Model C6Z1218M3-5
- 2. Application For 2/3 Format CCTV Camera
- 3. Specification

3-1. Physical (As per the attached drawing)

- (1) Dimensions 101.5(W) mm × 92.2(H) mm × 94.5(D) mm
- (2) Weight 635g
- (3) Mount C-Mount , Position Adjustable
- (4) Filter Screw Size 49 mm , P=0.75 mm

3-2. Optical

- (1) Focal Length 12.5 mm to 75 mm
- (2) Max . Aperture Ratio 1 : 1.8
- (3) Iris Range F/1.8 to F/22 to Close
- (4) Angle of View

	WIDE	TELE
Diagonal	47.94 °	8.30 °
Horizontal	38.72 °	6.67 °
Vertical	29.25 °	5.02 °

- (6) Picture format 8.8 mm × 6.6 mm
- (7) Focusing Range Inf. to 1 m
- (8) Back Focal Length 18.41 mm
- (9) Flange Back Length 17.526 mm ± 0.05 mm

3-3. Electrical

- (1) Operational
  - 1. Control Voltage & Current 
 Zooming & Focusing:  
 DC 12V 40mA or less/Motor ( at 25 )  
 Adjustable Voltage Range DC 6V to DC 12V  
 Iris:  
 DC 12V 35mA or less/Motor ( at 25 )  
 Adjustable Voltage Range DC 6V to DC 12V
  - 2. Control Method Polarity Switching Type
  - 3. Operational Speed 
 5.0 sec.(approx.) for Zooming  
 5.0 sec.(approx.) for Focusing  
 4.0 sec.(approx.) for Iris
  - 4. Connector 
 DIN 8-pin Connector  
 (E8-760P-100 made by Chuomusen)

**(2) Connection Diagram**

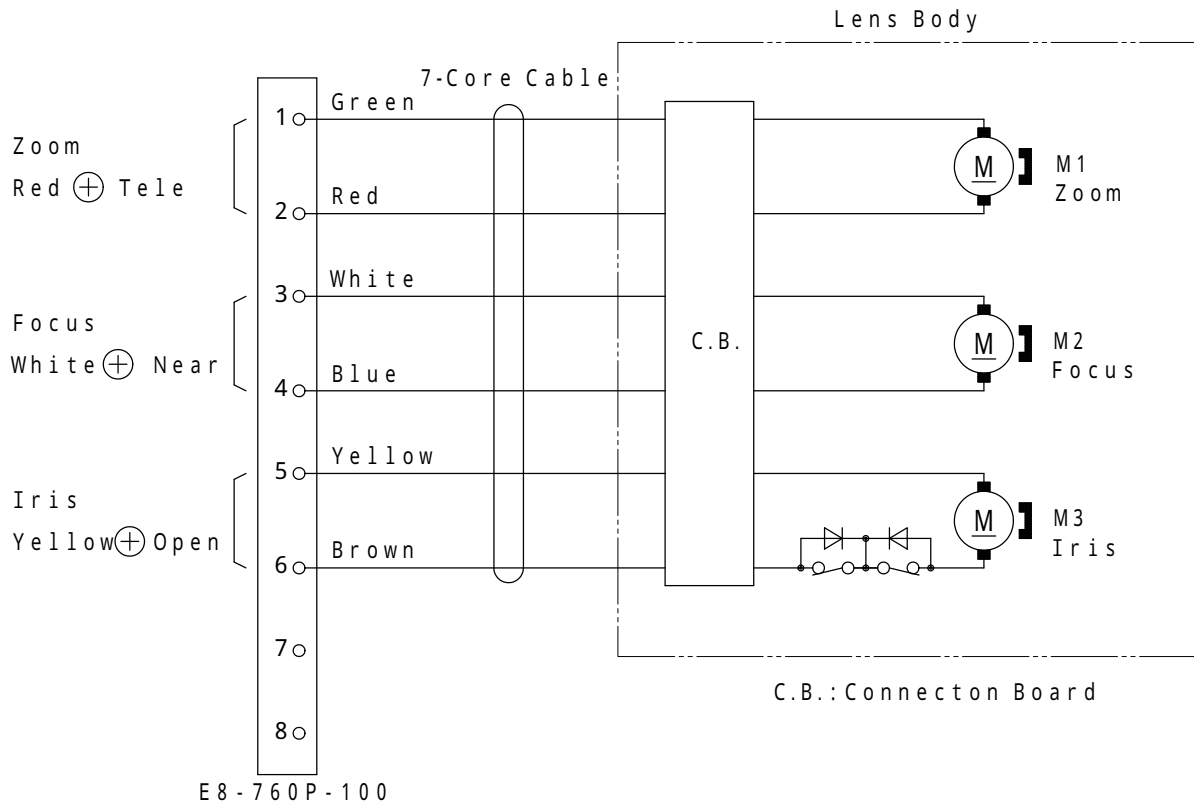

**4. Accessories**

- |                    |  |
|--------------------|--|
| (1) Front Lens Cap | 1 piece  |
| (2) Rear Lens Cap  | 1 piece  |
| (3) Connector      | DIN 8-pin Connector<br>(D8-760J-100 made by Chuomusen) 1 piece |
| (4) Packing Box    | 1 piece  |

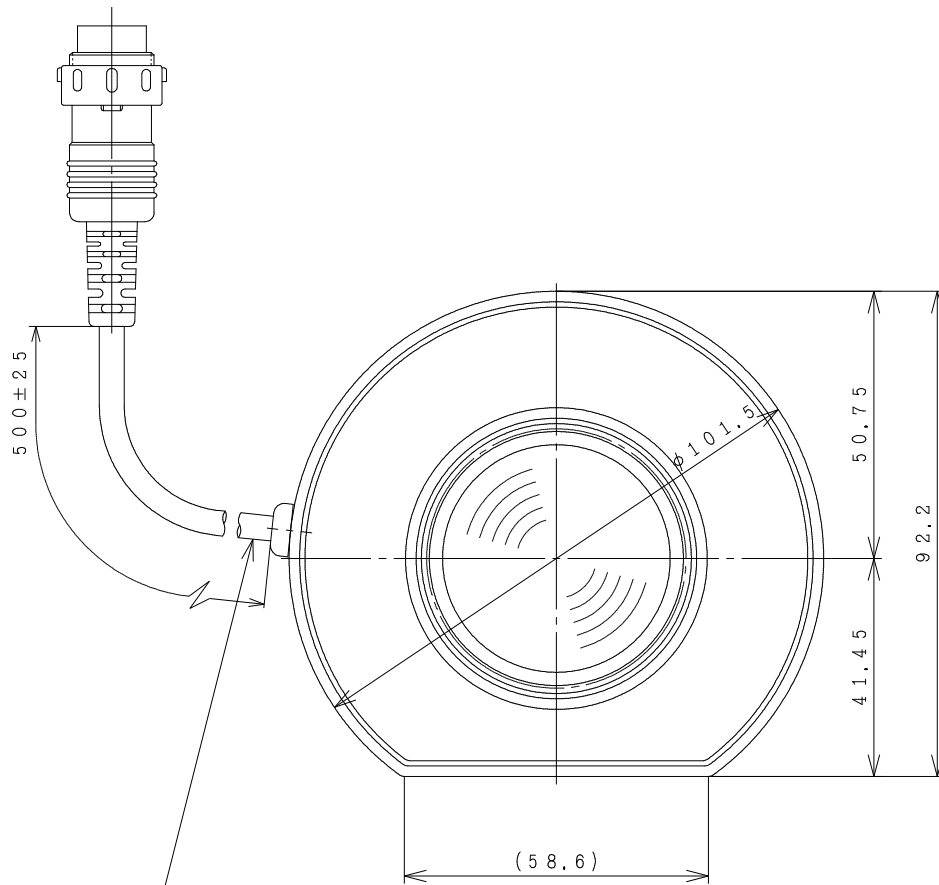

7-Core Cable for Zoom,  
Focus & Iris Control

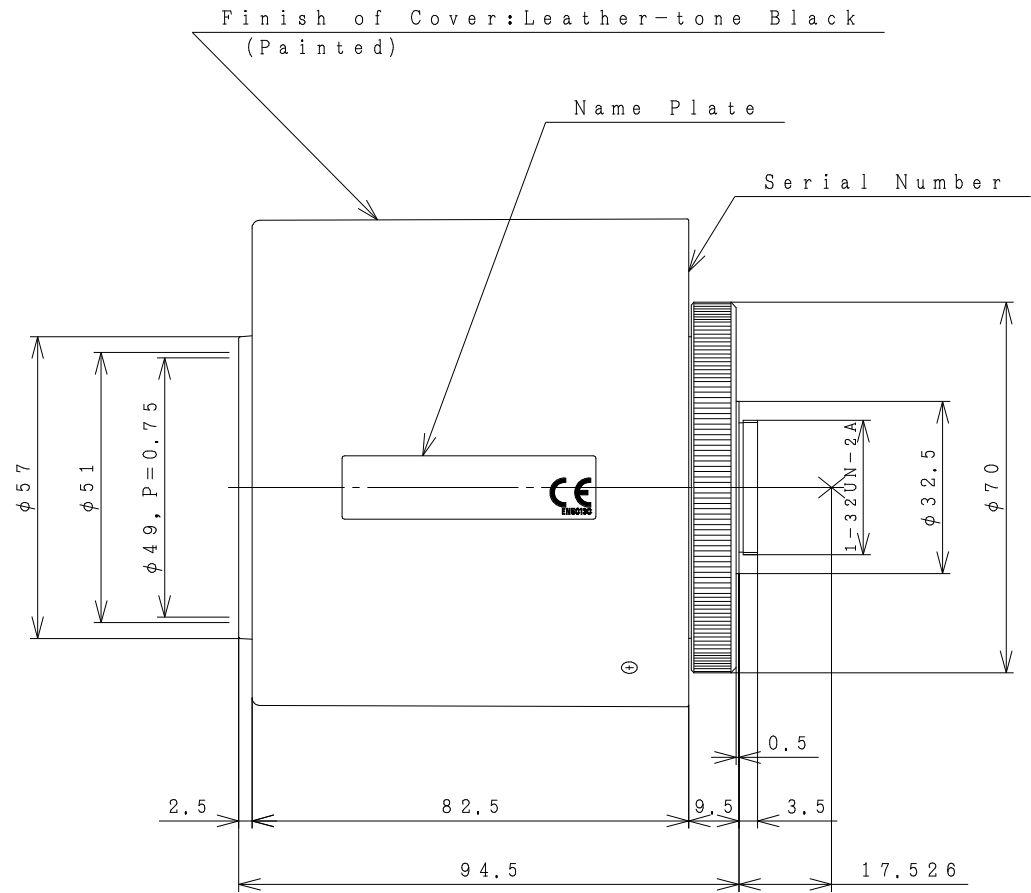

Finish of Cover: Leather-tone Black  
(Painted)

Name Plate

Serial Number

UNIT : mm

3					尺度	個数		
2					N. T. S.			
1					名称			
	訂	正	記	事	年月日	担当	C6Z1218M3-5	
承認	設計	製図	検図	完図	NOV 24, '04		External View	
					年月日		図面番号	
PENTAX Corporation Security System Division								31225-X501-000Z-B33