

镜头参数 (Parameter of Lens)

型号 (Model) :

C-M20 (12MP) -1F14



分辨率 (Resolution)	12 Megapixel		
像面尺寸 (Image format)	1.1"		
焦距 (Focal length)	20±5%mm		
通光孔径 (Aperture)	F1.6±5%		
接口 (Mount)	C		
视场角 (Field Angle) D×H×V(°) ±5%	1.1 (IMX428)	1 (IMX305)	1 (16*12.8*9.6)
	D 49.06	44.6	44.3
	H 42.4	39.4	35.7
V 27.96	21.0	26.8	
畸变 (Optical Distortion)	-4.9% Φ 16mm		
主光束入射角 (CRA)	≤6.1° Φ 16mm		
最近物距 (M. O. D.)	0.5m		
外形尺寸 (Dimension)	φ 45×67.7mm		
重量 (Weight)	212±5g		
法兰后焦距 (Flange BFL)	17.526mm		
光学后焦距 (BFL)	12.474mm (in air)		
机械后焦距 (MBF)	13.5mm (in air)		
日夜共焦 (IR Correction)	NO		
操作方法 (Operation)	光圈 (Iris)	手动光圈 (Manual)	
	聚焦 (Focus)	手动聚焦 (Manual)	
	变焦 (Zoom)	/	
工作温度 (Operating temperature)	-30℃~+70℃		

尺寸 (Size)

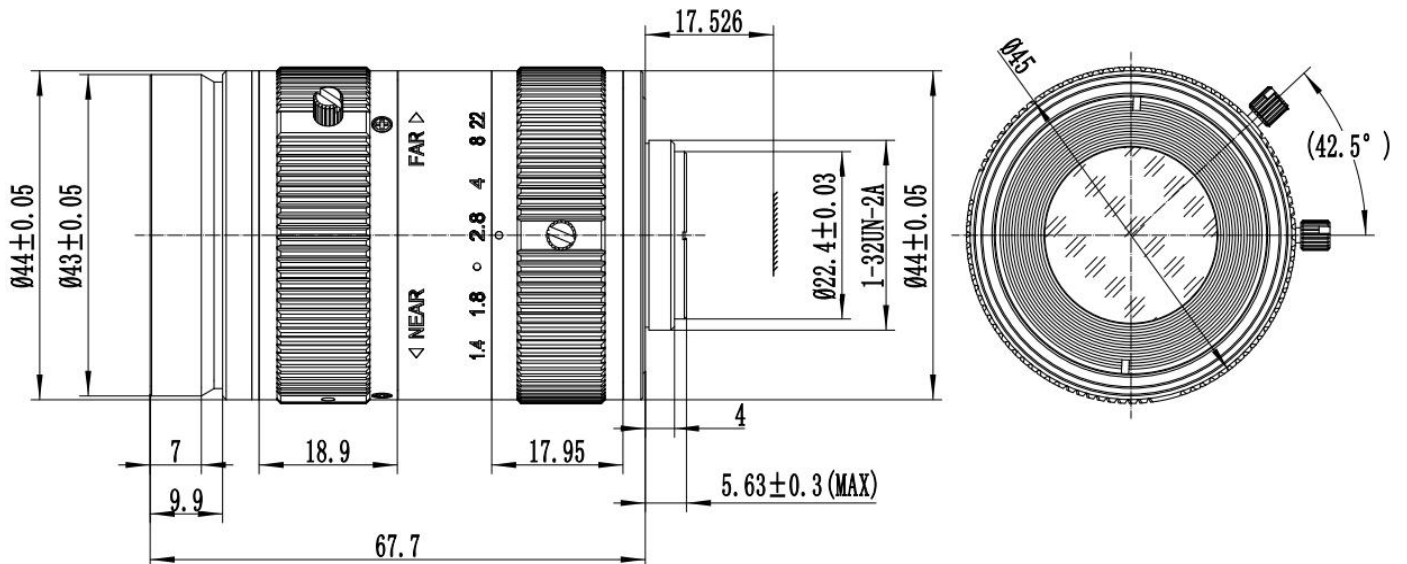

尺寸公差 Size tolerance (mm) :

0-10±0.05

10-30±0.10

30-120±0.20

角度公差 Angle tolerance

±2°



检测标准 (Test Standard)

型号 (Model) :		C-M20 (12MP)-1F14	
检测项目 Test Items		检测内容 Test Content	
1	逆投影检测 Resolution Test	Test Range	Φ16 (projection distance 1.5m, Window thickness 1.5±0.2mm)
		Center ≥	160 lp/mm
		Φ16 ≥	(Φ12) 125 lp/mm (Φ16) 100 lp/mm
		Image standard	The image should be clear.
2	外观检测 Appearance Inspection	Apperance (Inner barrel)	60-40: The maximum scratch width is allowed to be 0.06mm, the length allows the 1/4 edge position of the lens; the visually invisible fineness is negligible; the maximum diameter of the pip is allowed to be 0.2mm, and only one lens surface is allowed; the pip is smaller than 0.002mm~0.005m can be neglected; the film color is uniform; there is no obvious color spot on the surface.
		Apperance (Outer barrel)	The lens barrel has no obvious color difference, scratch, break, deformation; the glue is not allowed to overflow into the effective light path; no word drop, clear writing, the same font size, even spacing, etc.
		Rotation	Feel the rotation back and forth smoothly without jumping, stuck and abnormal sounds, etc
	环境 Environment	25±2℃ 700~1000 lux	



环境可靠性测试 (Reliability and Environmental Testing)

型号 (Model) :

C-M20 (12MP) -1F14

检测项目 Test Items

检测内容 Test Content

1

温度循环试验
Temperature Cycling Test

镜头在试验温度(-30±3)℃放置1.5小时, (70±3)℃放置3小时的条件下, 放置2个循环。试验后, 将镜头放置于室温24小时后进行检验, 各指标均合格。

Lens is placed on two cycles in the test temperature (-30±3)℃ for 1.5 hours and in (70±3)℃ for 3 hours separately. Then, the indicators are qualified after placing the lens at room temperature for 24 hours.

2

高温高湿试验
Damp heat test

镜头在试验温度(70±3)℃, 湿度85%RH的条件下, 放置48小时。试验后, 将镜头放置于室温24小时后进行检验, 各指标均合格。

Lens is placed in the test temperature (70±3)℃, humidity 85% RH for 48 hours. Then, the indicators are qualified after placing the lens at room temperature for 24 hours.

3

跌落试验
Drop Test

镜头在1米高(±0.1米)处, 自由跌落到混凝土地板上。试验后, 镜头各指标均合格。

Lens drops from the height of (1±0.1m) to the concrete ground. After the testing, the indicators are qualified.

4

振动试验
Vibration Test

镜头正弦波振动2小时, 在振幅为1mm, 频率为50Hz的条件下, 试验后, 镜头各指标均合格。

Lens vibrates 2h in sinusoidal wave under 1 mm of amplitude and 50Hz of frequency. After the testing, the indicators are qualified.

包装规格 (Packing Specification)

型号 (Model) :

C-M20 (12MP) -1F14

1. Stick label on the surface of lens after capped.
2. Put the lens into the carton box.
3. The unit will be packaged in a corrugated box.
4. Seal the corrugated box with tape and mark the surface.

