

BMH-S18

2MP HD-SDI Mini Box Camera



Features

- 1/2" 2MP Sony CMOS sensor
- 1080p 60fps / 30fps, 720p 60fps
- HD-SDI, EX-SDI, CVBS, TVI
- x32 Digital Zoom
- Real-time True WDR
- Digital Noise Reduction(2D+3D)
- Digital Slow Shutter
- Digital Image Stabilizer
- Privacy Mask Function
- High Light Compensation
- Defog Function
- ACE(Digital WDR)
- Motion Detection
- C/CS Mount

CAMERA	
Image Sensor	1/2" Sony CMOS Sensor
Total Pixels	1952(H) x 1241(V) = 2.42M Pixels
Active Pixels	1937(H) x 1097 (V) = 2.12M Pixels
Scanning System	Progressive Scan
Resolution	Digital : 1080p/60(50)fps, 1080p/30(25)fps, 720p/60(50)fps, 720p/30(25)fps
Min. Illumination	Color(1/30s) : 0.15 lux , BW(1/30s) : 0.01lux Color DSS(1/7.5s) : 0.0375 lux , BW DSS(1/7.5s) : 0.002 lux
S/N Ratio	more than 50dB (AGC off)
Video Output	HD-SDI, EX-SDI, CVBS

LENS	
Lens Type	C/CS mount lens

CAMERA FUNCTIONS	
Camera Title	ID / Title / Zoom Ratio / System Message
Day & Night	Auto / Day / Night / Ext-in
WDR/BLC	OFF / WDR / BLC / HLC
ACE	Off / Low / Middle / High
DNR	Auto / Off / Low / Middle / High
Defog	Off / On(Auto / Manual)
Digital Image Stabilizer	Off / On
Motion Detection	Off / On (3 positions)
Privacy Mask	Off / On (24 positions)
Digital Slow Shutter	Off /x2 /x4 (/ x8 : 60 or 50fps mode only)
Gain Control	Off / On
White Balance	Auto / One Push / Manual / Indoor / Outdoor
Shutter Speed	1/30(25) ~ 1/30,000 sec
E.Zoom	Off / x2 ~ x32
Digital Flip	Off / H / V / H&V

Dimensions

Unit : mm

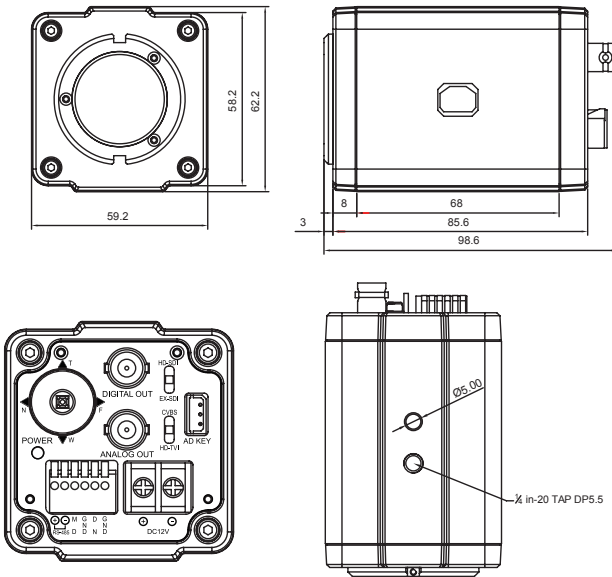

GENERAL	
Power Source	DC12V±10%
Power Consumption	250mA
Operating Temperature	-10°C ~ +50°C / 0% ~ 90% RH
Dimensions	59.2(W) x 62.2(H) x 98.6(D) mm
Weight	0.24Kg