

1/2" High Sensitivity Camera BMH-S128



2MP x12 AF HD-SDI Box Camera



Features

- 1/2" 2MP Sony CMOS sensor
- 1080p@60/50fps, 1080p@30/25fps, 720p@60/50fps, 720p@30/25fps
- HD-SDI, EX-SDI, TVI, CVBS
- x12 Optical Zoom(7mm~84mm) & x32 Digital Zoom
- AutoFocus
- Real-time True WDR
- Digital Noise Reduction(2D+3D)
- Digital Slow Shutter
- Digital Image Stabilizer
- Privacy Mask Function
- High Light Compensation
- Defog Function
- ACE(Digital WDR)
- Motion Detection
- Protocol(VISCA, Pelco-D, Pelco-P)

Dimensions

Unit : mm

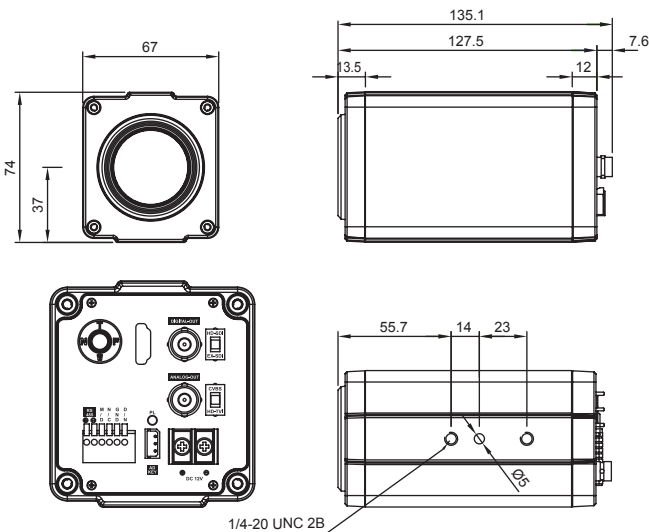

CAMERA	
Image Sensor	1/2" Sony CMOS Sensor
Total Pixels	1952(H) x 1241(V) = 2.42M Pixels
Active Pixels	1937(H) x 1097 (V) = 2.12M Pixels
Video Format	1080p@60/50fps, 1080p@30/25fps, 720p@60/50fps, 720p@30/25fps
Min. Illumination	Color(1/30s) : 0.15 lux , BW(1/30s) : 0.01lux
	Color DSS(1/7.5s) : 0.0375 lux , BW DSS(1/7.5s) : 0.002 lux
S/N Ratio	more than 50dB (AGC off)
Video Output	HD-SDI, EX-SDI, TVI, CVBS

LENS		x12		
Lens Type	x12 Day & Night Zoom Lens			
Zoom Ratio	Optical x12, Digital x32 Zoom			
Focal Length	f = 7.0mm ~ 84mm			
Aperture Ratio	F1.5 (wide) ~ F1.9 (tele)			
Angle Of View (D, H, V)	WIDE	58.3°	51.1°	30°
	TELE	6.5°	5.0°	3.2°

CAMERA FUNCTIONS	
Camera Title	ID / Title / Zoom Ratio / System Message
Day & Night	Auto / Day / Night / Ext-in
WDR/BLC	Off / WDR / BLC / HLC
ACE	Off / Low / Middle / High
DNR	Auto / Off / Low / Middle / High
Defog	Off / On(Auto / Manual)
Digital Image Stabilizer	Off / On
Motion Detection	Off / On (3 positions)
Privacy Mask	Off / On (24 positions)
Digital Slow Shutter	Off /x2 /x4
Gain Control	Off / On
White Balance	Auto / One Push / Manual / Indoor / Outdoor
Shutter Speed	1/30(25) ~ 1/30,000 sec
E.Zoom	Off / x2 ~ x32
Digital Flip	Off / H / V / H&V

GENERAL	
Power Source	DC12V±10%
Power Consumption	Max 500mA
Operating Temperature	-10°C ~ +50°C / 0% ~ 90% RH
Dimensions	67(W) x 74(H) x 135.1(D) mm
Weight	0.57Kg