

BMH-308

2MP 30x AF HD-SDI Box Camera

HD-SDI
EX-SDI



Features

- 2MP High Resolution Video output
- HD-SDI, EX-SDI, TVI, CVBS
- 30x Optical Zoom(4.3~129mm) & 32x Digital Zoom
- Real-time True WDR
- Digital Noise Reduction(2D+3D)
- Digital Slow Shutter
- Digital Image Stabilization
- Privacy Mask Function
- High Light Compensation
- Defog Function
- ACE(Digital WDR)
- Motion Detection
- Protocol(VISCA, Pelco-D, Pelco-P)

Dimensions

Unit : mm

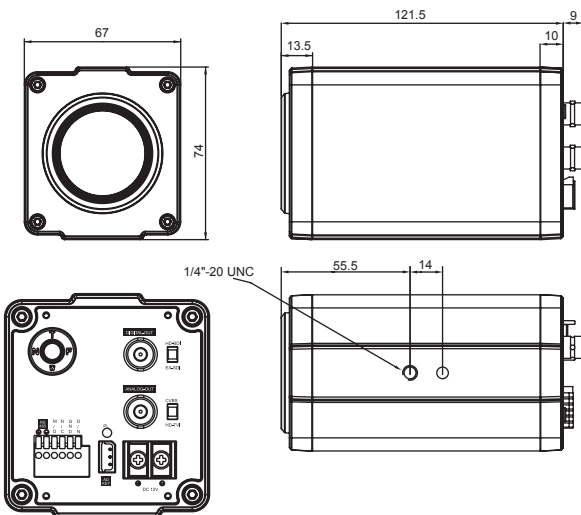

MODEL		BMH-308		
CAMERA				
Image Sensor	1/3" Panasonic CMOS Sensor			
Total Pixels	1981 (H) x 1288 (V) = 2.55M Pixels			
Active Pixels	1944 (H) x 1212 (V) = 2.35M Pixels			
Video Format	1080p@60/50fps, 1080p@30/25fps, 720p@60/50fps, 720p@30/25fps			
Min. Illumination	Color	0.05 lux / DSS 0.002 lux		
	BW	0.005lux / DSS 0.0001 lux		
S/N Ratio	more than 50dB (AGC off)			
Video Output	HD-SDI, EX-SDI, TVI, CVBS			
LENS		30x		
Lens Type	30x Day & Night Zoom Lens			
Zoom Ratio	Optical 30x, Digital 32x Zoom			
Focal Length	f = 4.3 mm ~ 129.0 mm			
Aperture Ratio	F1.6 (wide) ~ F4.7 (tele)			
Angle Of View (D, H, V)	WIDE	72.9°	65.1°	38.4°
	TELE	2.64°	2.34°	1.36°
CAMERA FUNCTIONS				
Camera Title	ID / Title / Zoom Ratio / System Message			
Day & Night	Auto / Day / Night / Ext-in			
WDR/BLC	Off / WDR / BLC / HLC			
ACE	Off / Low / Middle / High			
DNR	Auto / Off / Low / Middle / High			
Defog	Off / On(Auto / Manual)			
Image Stabilization	Off / On			
Motion Detection	Off / On (3 positions)			
Privacy Mask	Off / On (24 positions)			
Digital Slow Shutter	Off / x2 / x4 / x8 / x16 / x32			
Gain Control	Off / On			
White Balance	Auto / One Push / Manual / Indoor / Outdoor			
Shutter Speed	1/30(25) ~ 1/30,000 sec			
E.Zoom	Off / x2 ~ x32			
Digital Flip	Off / H / V / H&V			
GENERAL				
Power Source	DC12V±10%			
Power Consumption	Max 500mA			
Operating Temperature	-10°C ~ +50°C / 0% ~ 90% RH			
Dimensions	67(W) x 74(H) x 130.5(D) mm			
Weight	0.57Kg			