

## 产品技术规格书 (Product Technical Specification)

No.	名称 (Name)	规格 (Specification)	No.	名称 (Name)	规格 (Specification)	
1	型号 (Model)	AZURE-NV2520SWIR	14	视场角 F.O.V.(DxVxH)	°" 1.8 4/3 1	
2	物料代码 (Material Code)	3. A01.01NV2520SWIR-A			D 56.2 48.04 35.49	
3	靶面格式 (Image Format)	28mm			H 48.2 39.19 28.72	
4	分辨率 (Resolution)	12.5 μm			V 32.4 29.8 21.74	
5	焦距 (Focal Length)	25mm	15	接口 (Mount)	C	
6	后截距 (Back Focus)	15.07mm	16	适用物距 (Suitable Distance)	0.25-∞m	
7	F值 (F/No.)	2.0	17	最佳物距 (Optimum Working Distance)	0.5m	
8	光圈 (Iris Type)	Manual	18	镀膜 (Coating)	800nm-1700nm	
9	畸变 (Distortion)	<-2.3%	19	外形尺寸 (Dimension)	φ44×48.53mm	
10	通光口径 (Lens Effective Diameter)	前面 (Front)	φ27.37mm	20	重量 (Weight)	195g
		后面 (Back)	φ16.37mm	21	工作温度 (Operating Temperature)	-20°C~+65°C
11	相对照度 (Relative Illuminate)	43%	22	镜头组成 (Lens Construction)	9-6	
12	光学总长 (TTL)	64mm	23	最大主光线入射角 (CRA)	25.05°	
13	设计波长 (Design Wavelength)	900~1700nm	24	滤镜尺寸 (Filter Thread)	M40.5×0.5	

Size:

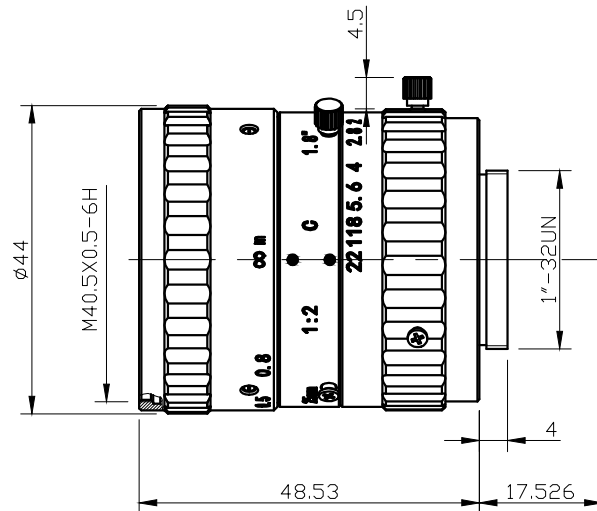

Unit:mm

Draw	Check	Recheck	Approval	福建浩蓝光电有限公司 AZURE Photonics Co.,Ltd