

产品技术规格书 (Product Technical Specification)

No.	名称 (Name)	规格 (Specification)	No.	名称 (Name)	规格 (Specification)	
1	型号 (Model)	AZURE-8528UV	14	视场角 F.O.V.(DxVxH)	(25mm) 1 2/3	
2	物料代码 (Material Code)	3. A01. 010852801			D	14.06 9.04 6.24
3	靶面格式 (Image Format)	25mm			H	11.28 7.25 4.98
4	分辨率 (Resolution)	65 lp/mm			V	8.46 5.44 3.74
5	焦距 (Focal Length)	85mm	15	接口 (Mount)	F	
6	后截距 (Back Focus)	43.34mm	16	适用物距 (Suitable Distance)	0.4-∞m	
7	F值 (F/No.)	2.8	17	最佳物距 (Optimum Working Distance)	0.7m	
8	光圈 (Iris Type)	Manual	18	镀膜 (Coating)		
9	畸变 (Distortion)	<1.45%	19	外形尺寸 (Dimension)	φ62×82.73mm	
10	通光口径 (Lens Effective Diameter)	前面 (Front)	φ37.34mm	20	重量 (Weight)	g
		后面 (Back)	φ22.03mm	21	工作温度 (Operating Temperature)	-20°C~+65°C
11	相对照度 (Relative Illuminate)	82.34%	22	镜头组成 (Lens Construction)	7-7	
12	光学总长 (TTL)	135.17mm	23	最大主光线入射角 (CRA)	11.2°	
13	设计波长 (Design Wavelength)	250~400nm	24	滤镜尺寸 (Filter Thread)	M52X0.75	

Size:

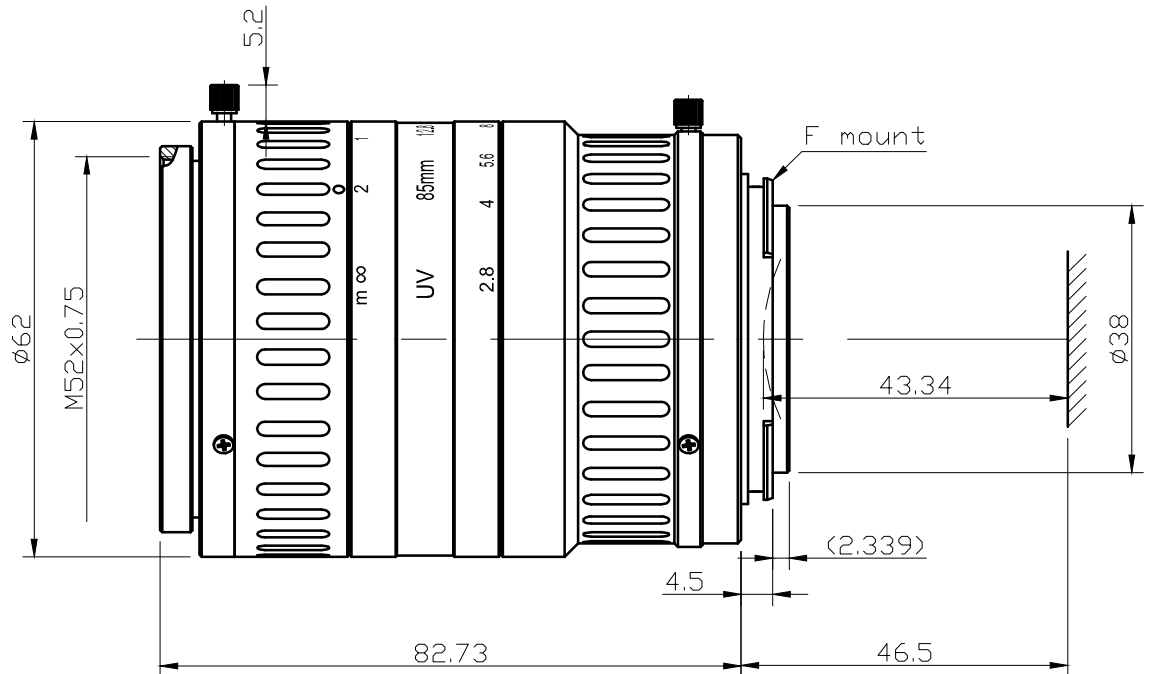

Unit:mm

Draw	Check	Recheck	Approval	福建浩蓝光电有限公司 AZURE Photonics Co.,Ltd