

产品技术规格书 (Product Technical Specification)

No.	名称 (Name)	规格 (Specification)	No.	名称 (Name)	规格 (Specification)	
1	型号 (Model)	AZURE-3520ML12M	14	视场角 F.O.V (DxVxH)	1.1" 2/3 1/2	
2	物料代码 (Material Code)	3. A01. 043520L12-A			D	25.27 15.89 11.59
3	靶面格式 (Image Format)	1.1"			H	20.4 12.89 9.35
4	分辨率 (Resolution)	150lp/mm			V	15 9.64 7.0
5	焦距 (Focal Length)	35mm	15	接口 (Mount)	C	
6	后截距 (Back Focus)	13.16mm	16	适用物距 (Suitable Distance)	0.2~∞m	
7	F值 (F/No.)	2.0	17	最佳物距 (Optimum Working Distance)	0.35m	
8	光圈 (Iris Type)	Manual	18	镀膜 (Coating)	400-900nm	
9	畸变 (Distortion)	<0.15%	19	外形尺寸 (Dimension)	φ46×77.1mm	
10	通光口径 (Lens Effective Diameter)	前面 (Front)	φ29.22mm	20	重量 (Weight)	g
		后面 (Back)	φ14.88mm	21	工作温度 (Operating Temperature)	-20~+65℃
11	相对照度 (Relative Illuminate)	62.2%	22	镜头组成 (Lens Construction)	12-8	
12	光学总长 (TTL)	79.23-92.33mm	23	最大主光线入射角 (CRA)	15.06°	
13	设计波长 (Design Wavelength)	400-700nm	24	滤镜尺寸 (Filter Thread)	M37.5×0.5	

Size:

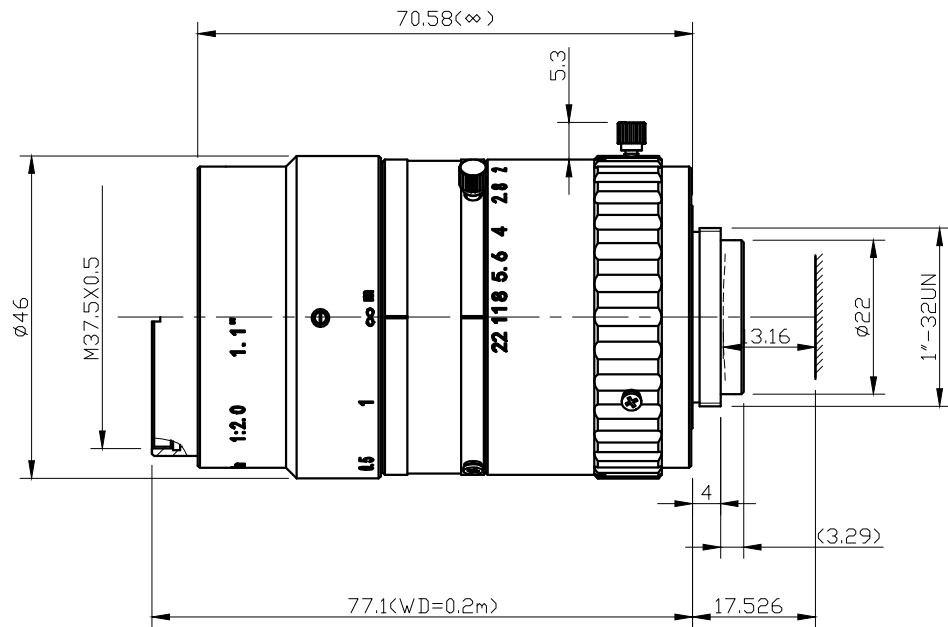

Unit:mm

Draw	Check	Recheck	Approval	福建浩蓝光电有限公司 AZURE Photonics Co.,Ltd