

## 产品技术规格书 (Product Technical Specification)

No.	名称 (Name)	规格 (Specification)	No.	名称 (Name)	规格 (Specification)	
1	型号 (Model)	AZURE-5020SWIR-S	14	视场角 F.O.V.(DxVxH)	2/3" 1/2 1/3	
2	物料代码 (Material Code)	3. A01. 010003-A			D	12.36 9.04 6.78
3	靶面格式 (Image Format)	2/3"			H	9.92 7.24 5.42
4	分辨率 (Resolution)	30lp/mm			V	7.45 5.42 4.08
5	焦距 (Focal Length)	50mm	15	接口 (Mount)	C	
6	后截距 (Back Focus)	9.78mm	16	适用物距 (Suitable Distance)	0.4-∞m	
7	F值 (F/ No.)	2.0	17	最佳物距 (Optimum Working Distance)	1.5m	
8	光圈 (Iris Type)	Manual	18	镀膜 (Coating)	800nm-1700nm	
9	畸变 (Distortion)	<-0.16%	19	外形尺寸 (Dimension)	φ 38.5 × 44.94mm	
10	通光口径 (Lens Effective Diameter)	前面 (Front)	φ 24.09mm	20	重量 (Weight)	152g
		后面 (Back)	φ 12.55mm	21	工作温度 (Operating Temperature)	-20°C ~ +65°C
11	相对照度 (Relative Illuminate)	73.2%	22	镜头组成 (Lens Construction)	6-4	
12	光学总长 (TTL)	55.9mm	23	最大主光线入射角 (CRA)	5.42°	
13	设计波长 (Design Wavelength)	900~1700nm	24	滤镜尺寸 (Filter Thread)	M35.5 × 0.5	

Size:

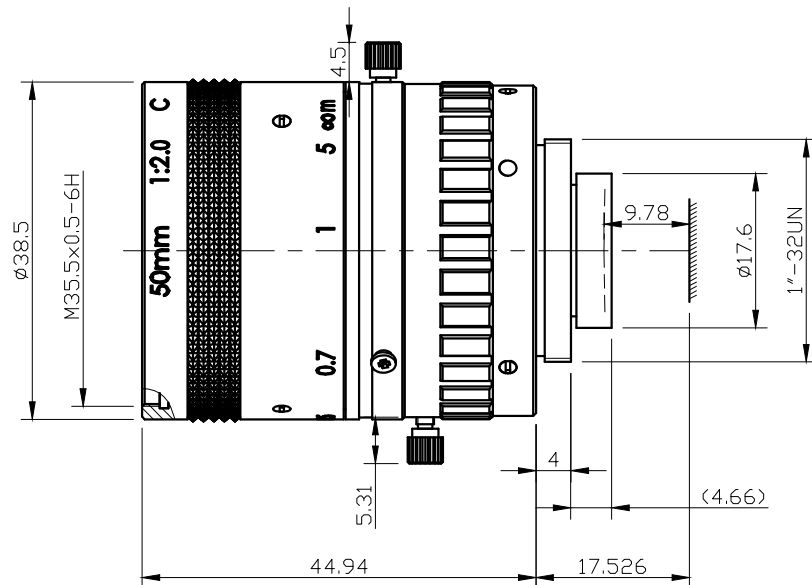

Unit:mm

Draw	Check	Recheck	Approval	福建浩蓝光电有限公司 AZURE Photonics Co.,Ltd