

Prosilica GT

4096



- Type APS-H CMOS sensor
- IEEE 1588 PTP
- Power over Ethernet
- 7.18 fps @ full resolution

Description

16.7 Megapixel CMOS camera for extended temperature ranges - GigE Vision®

Prosilica GT4096 is a 16.7 Megapixel camera with a GigE Vision compliant Gigabit Ethernet interface and Hirose port. Prosilica GT4096 is offered as monochrome and extended near-infrared (NIR) models. This camera incorporates the high quality ON Semiconductor PYTHON 16K CMOS sensor with In-pixel Correlated Double Sampling (IP-CDS) global shutter technology. Prosilica GT4096 a rugged camera with a robust thermal housing that is designed to operate in extended temperature ranges and fluctuating lighting conditions. It is a large format housing camera with a standard F-Mount lens mount. By default monochrome and NIR models ship with no optical filter.

Benefits and features:

- Monochrome (GT4096) and extended near-infrared (GT4096NIR) models
- GigE Vision interface with Power over Ethernet
- The ON Semiconductor PYTHON 16K is a high sensitivity CMOS sensor
- Trigger over Ethernet (ToE) Action Commands allows for a single cable solution
- Planarity adjustable (PA) EF Lens Mount (option -18) for electronic control of aperture and autofocus
- Support for popular third party image-processing libraries including Cognex, MathWorks MATLAB, and National Instruments LabVIEW
- Enhanced Defect Pixel Correction feature with a new Defective Pixel List Manager tool that allows you to load different user defined defective pixel lists to match your application and optimize the life cycle of the camera

Options:

- Available with F-Mount PA, M58-Mount, M58-Mount PA, EF-Mount PA, M42-Mount, M42-Mount PA
- Available with IR cut filter or protection glass

See the Modular Concept for additional information on lens mount and optical filter options.

Specifications

Prosilica GT	4096
Interface	IEEE 802.3 1000BASE-T, IEEE 802.3af (PoE)
Resolution	4096 (H) × 4096 (V)
Sensor	ON Semi PYTHON 16K
Sensor type	CMOS
Cell size	4.5 μm x 4.5 μm
Lens mount	F-Mount
Max frame rate at full resolution	7.18 fps
ADC	10 bit
Image buffer (RAM)	128 MByte
Output	
Bit depth	10 bit
Mono modes	Mono8, Mono10
General purpose inputs/outputs (GPIOs)	
TTL I/Os	1 input, 2 outputs
Opto-isolated I/Os	1 input, 2 outputs
RS-232	1
Operating conditions/dimensions	
Operating temperature	-20 °C to +50 °C ambient (without condensation)
Power requirements (DC)	7 to 25 VDC; PoE
Power consumption (@12 V)	5.0 W @ 12 VDC; 6.4 W PoE
Mass	372 g
Body dimensions (L × W × H in mm)	96 × 66 × 53.3 (including connectors)
Regulations	CE, RoHS, REACH, WEEE, FCC, ICES

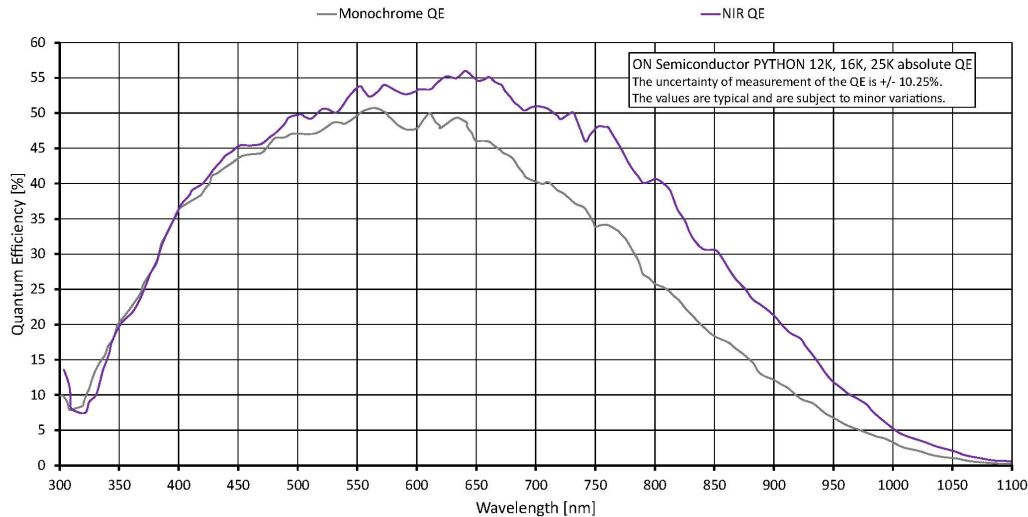

Features

Image optimization features:

- Auto gain (manual gain control: 0 to 22 dB)
- Auto exposure (manual exposure control: 100 μ s to 1 s, 1 μ s increments)
- Binning (horizontal and vertical) (sum)
- Decimation X/Y
- Enhanced Defect Pixel Correction (DPC)
- Fixed Pattern Noise Correction (FPNC)
- Gamma correction
- Four look-up tables (LUTs)
- Region of interest (ROI)

Camera control features:

- EF lens control (order option -18)
- Event channel
- Image chunk data
- IEEE 1588 Precision Time Protocol (PTP)
- RS232
- Storable user sets
- StreamBytesPerSecond (easy bandwidth control)
- Stream hold
- Sync out modes: Trigger ready, input, exposing, readout, imaging, strobe, GPO

- Temperature monitoring (main board and sensor board)
- Trigger over Ethernet (ToE) Action Commands

Technical drawing

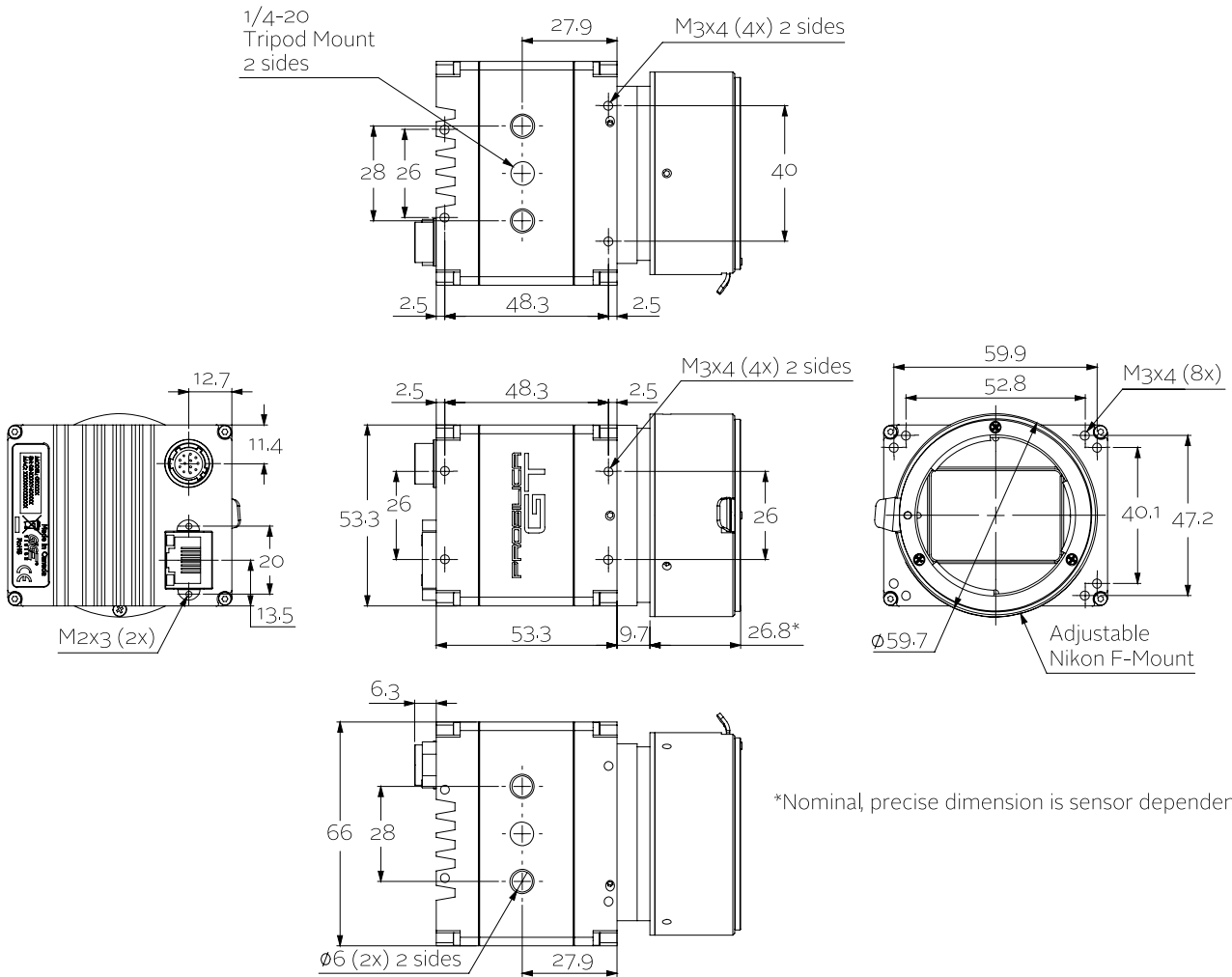



Applications

Prosilica GT4096 camera series is ideal for a wide range of applications including:

- Outdoor imaging
- Intelligent Traffic Systems (ITS)
- Public security and surveillance
- Industrial inspection (food, bottles, recycling, labels, etc.)
- Microscopy
- Military and space applications
- Medical and healthcare
- Other machine vision applications