

BRC-300/BRC-300P

3CCD Color Video Camera

SONY[®]

3CCD Color Video Camera



THE NEW WAY OF BUSINESS™

MAIN FEATURES



Sony's new BRC-300 is a revolutionary all-in-one compact robotic color video camera system, specially designed for remote video shooting applications. The BRC-300 incorporates three 1/4.7-type Advanced HAD™ CCDs, that provide high-quality and high-resolution images in both 4:3 and 16:9 modes.

With its high-accuracy and wide-range Pan/Tilt/Zoom capability, the BRC-300 precisely captures the right points of the viewable area surrounding the camera to meet your needs. You can also easily operate the camera with Sony's optional RM-BR300 Remote Control Unit, which is equipped with an ergonomic joystick, and feature-rich control panel. And when used with optional BRBK-303 Optical Multiplex Card and BRU-300 Optical Multiplex Unit, the BRC-300 is capable of being controlled from a long distance with a single fiber optic cable connection.

The BRC-300 also comes equipped with a card slot that accepts optional interface cards, enabling the camera to be integrated into every kind of system from S-Video to RGB, i.LINK® DV interface, SDI or even fiber. In addition, two remote control interfaces (VISCA™ protocol) are available to provide additional expandability and flexibility for your remote shooting applications.

With a number of convenient features such as its E:Flip function for desktop or ceiling mount flexibility, and its compact body, the BRC-300 is ideal for use in a wide range of remote shooting applications such as houses of worship, distance learning, corporate training, high-end videoconference, event shooting, and cable TV broadcasting. Utilizing the optional BRC-SDP12 outdoor weatherproof housing, the BRC-300 is ideal for traffic and weather cam applications as well.



Superb Picture Quality

The BRC-300 incorporates three 1/4.7-type Advanced HAD CCD sensors with a total of 1,070,000 pixels. This camera delivers outstanding picture quality with high resolution and accurate color reproduction. Featuring Sony's Advanced HAD technology that produces images with low noise, the BRC-300 is ideal in low illuminated shooting environments or when shooting dark subjects.

High-performance Sony Pan/Tilt/Zoom Mechanism

The BRC-300 covers a wide shooting range with its highly accurate Pan/Tilt mechanism. It has one of the widest ranges in its class: a pan range of 340 degrees, and a tilt range of 120 degrees. The 340-degree pan range can be covered in 8 seconds, while the 120-degree tilt range can be covered in 4.5 seconds. With its newly developed Pan/Tilt mechanism, the BRC-300 can capture not only fast moving objects, but also slow moving objects without vibration.

What's more, the BRC-300 incorporates a 12x optical auto-focus zoom lens, allowing for a zoom capability of up to 48x when used in combination with its 4x digital zoom.

Note: In this brochure, "BRC-300" refers to both the BRC-300 (NTSC model) and the BRC-300P (PAL model), and "BRU-300" refers to both the BRU-300 (NTSC model) and the BRU-300P (PAL model).

Precision 16:9 technology

The BRC-300 captures images in both 4:3 and 16:9 aspect ratios, and with its 3 CCD technology, is able to achieve a wide angle of view in the 16:9 mode.

Due to the greater number of pixels used in the 16:9 aspect ratio, the BRC-300 generates extremely high-resolution images as compared to conventional cameras.

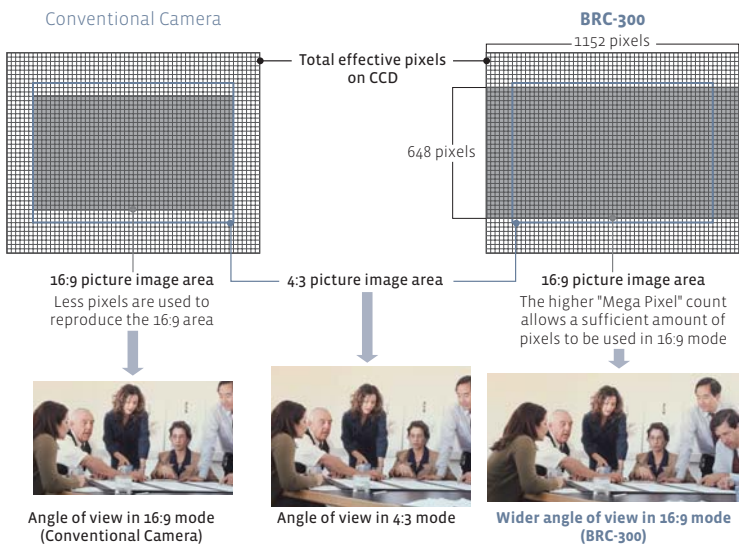

Fig. 1 16:9 aspect ratio

RS-232C/RS-422 Remote control (VISCA protocol)

The BRC-300 can be controlled by external devices such as the optional RM-BR300 Remote Control Unit thanks to Sony's well-known VISCA protocol. All local controls such as Pan/Tilt/Zoom, camera settings, and six presets can be easily accessed, and up to seven cameras can be daisy-chained and controlled by the RM-BR300 Remote Control Unit.

Versatile Video Outputs

The BRC-300 can be used with a range of versatile optional interface cards allowing for flexible analog and digital system configurations. Choose from the following interface cards to configure your individual requirements:

- Analog RGB/Component: BRBK-301*
- SDI: BRBK-302*
- DV i.LINK interface: BRBK-304
- Fiber Optic: BRBK-303 (for use in conjunction with BRU-300 Optical Multiplex Unit only)

Thanks to these convenient options, the BRC-300 truly functions as an all-in-one, compact robotic camera.

* Can be installed into the both BRC-300 and BRU-300



OTHER CONVENIENT FEATURES

Ceiling or Desktop Mount Installation

Thanks to Sony's E:Flip function, the BRC-300 can be ceiling mounted using the supplied ceiling mount kit or can also be used on the desktop.

Six Presets

Various camera settings such as Pan/Tilt/Zoom and focus can be preset in up to six presets per camera.

Multi-Function IR Remote Commander® Unit

Basic camera settings such as Pan/Tilt/Zoom functions and six-preset patterns can be controlled from the supplied remote commander.



Ergonomically designed Remote Control Unit (RM-BR300)

All camera settings including the Pan/Tilt/Zoom function and six preset patterns can be controlled from the optional RM-BR300 Remote Control Unit. The ergonomic joystick design and feature-rich control panel provide superb operability in various remote-shooting applications.

Optical Multiplex Unit (BRU-300)

The optional BRU-300 Multiplex Unit receives and converts uncompressed digital raw data from the camera using the optional multiplex interface card into virtually any video output format. The unit has two built-in interface card slots and can be connected to the camera with a single fiber cable that extends up to 1,500 feet for easy installation. The BRU-300 also converts control data from the RM-BR300 to optical, and transmits this data to the camera.



BRC-300 and supplied IR Remote commander



RM-BR300 control panel

SYSTEM CONFIGURATION

Short-distance operation

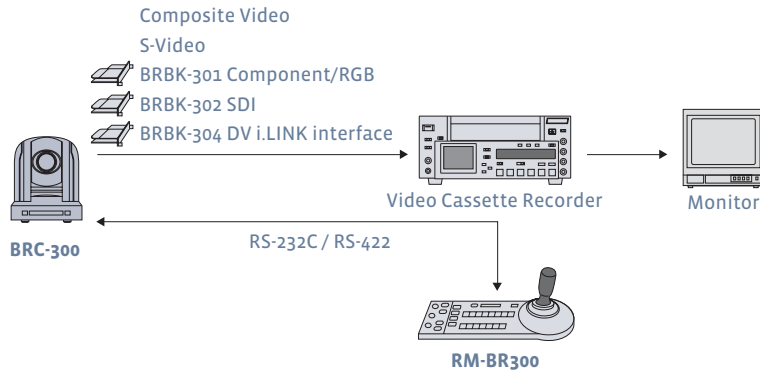

Long-distance operation

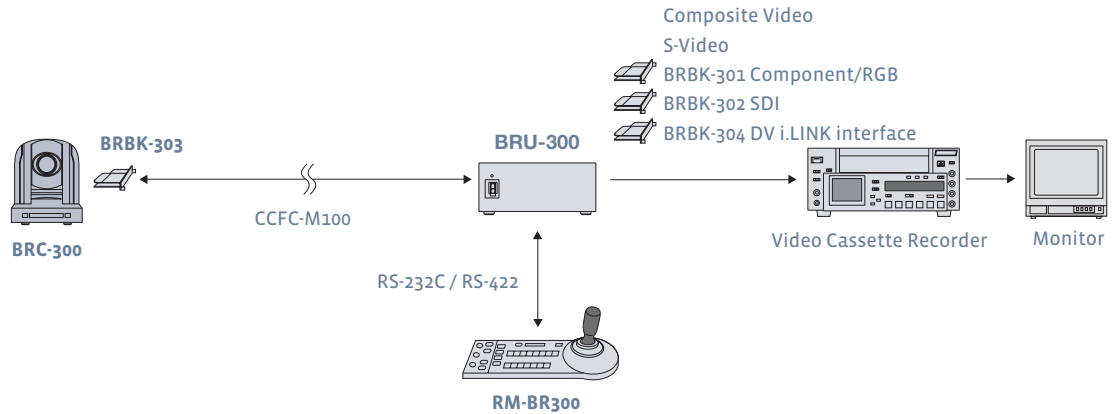

Multiple camera operation from a remote location

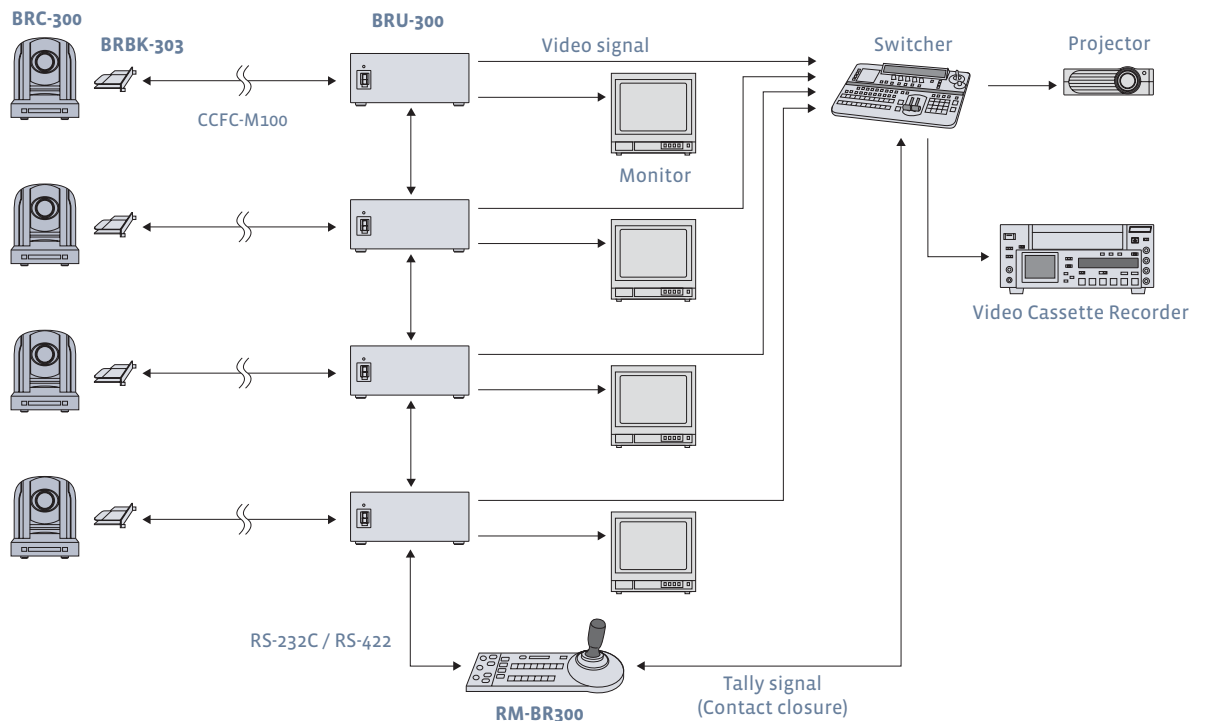

OPTIONAL ACCESSORIES



BRBK-301
Analog/RGB Component Card



BRBK-302
SDI Card



BRBK-303
Optical Multiplex Card



BRBK-304
DV i.LINK Interface Card



RM-BR300
Remote Control Unit



BRU-300
Optical Multiplex Unit



CCFC-M100
Optical Fiber Cable



CCMC-9DS
RGB/Component, Y/C Cable
(9-pin D-sub)



CCXC-9DBS/US
RGB/Component, VBS Cable
(9-pin D-sub)



VCL-0737W
Wide Conversion Lens



BRC-SDP12
Weatherproof Housing

REAR PANEL LAYOUT



BRU-300 rear panel with the optional BRBK-302



RM-BR300 rear panel



BRU-300 rear panel with the optional BRBK-301/BRBK-302

SPECIFICATIONS

BRC-300 3CCD Color Video Camera

Image device	Three 1/4.7 type IT Advanced HAD CCD (x3), 1070000 pixels (gross)	
CCD effective pixels	4:3 mode	960 (H) x 720 (V)
	16:9 mode	1,152 (H) x 648 (V)
Effective pixels	NTSC	768 (H) x 494 (V)
	PAL	752 (H) x 582 (V)
Signal systems	NTSC / PAL	
Horizontal resolution	4:3 mode	600 TV lines
Sync systems	Internal/External	
Lens	12x optical zoom, 48x with digital zoom	
Focal length	f = 3.6 to 43.2 mm (F1.6 to F2.8)	
Horizontal viewing angle	4:3 mode	3.3 (Tele end) to 37.8 degrees (Wide end)
	16:9 mode	4.0 (Tele end) to 45.4 degrees (Wide end)
Minimum object distance	300 mm (Wide end), 800 mm (Tele end)	
Pan/Tilt angle	-170 to +170 degrees (Pan), -30 to +90 degrees (Tilt)	
Pan/Tilt speed	0.25 to 60 degrees/s (Pan/Tilt)	
Minimum illumination	7 lx at F1.6	
S/N ratio	50 dB	
Shutter speed	NTSC	1/10000 to 1/4 s
	PAL	1/10000 to 1/3 s
Gain	Auto/Manual (-3 to 18 dB, 3 dB steps) switchable	
White balance	Auto, Indoor, Outdoor, One-push WB, Manual	
Preset positioning	6 positions	
Analog output	VBS (BNC), Y/C (4pin Mini DIN)	
Camera control interface	RS-232C (VISCA protocol) / RS-422 (VISCA protocol)	
Back-light compensation	On / Off	
Operating temperature	0 to 40 degrees (32 to 104 °F)	
Storage temperature	-20 to 60 degrees (-4 to 140 °F)	
Power requirement	DC 12 V	
Power consumption	21.6 W (without optional card)	
Dimensions (W x D x H)	7 1/8 x 8 1/8 x 8 3/8 inches (180 x 205 x 211 mm)	
Weight	5 lb 15 oz (2.7 kg)	
Supplied accessories	AC adaptor(1), IR remote commander(1), Terminal connector(1), AC adaptor cable(1), Ceiling bracket(2), Operating instructions(1)	

BRC-300 Dimensions

FRONT

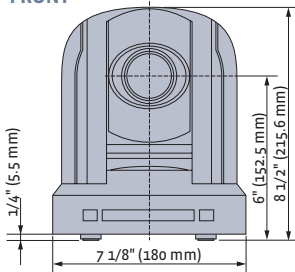

SIDE

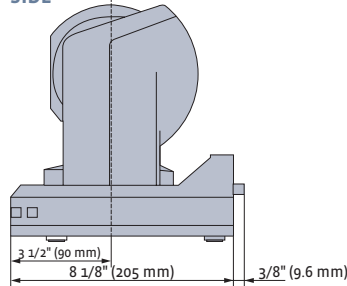

BOTTOM

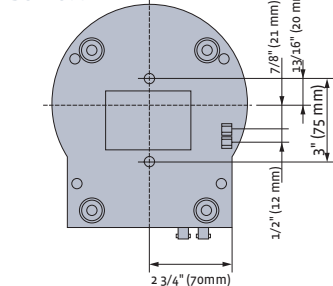

(Unit: inches/mm)

BRU-300 Optical Multiplex Unit

Optical fiber	Multi mode, LC-type connector	
Video output	VBS (BNC), Y/C (4-pin Mini DIN)	
Camera control interface	RS-232C (VISCA protocol) / RS-422 (VISCA protocol)	
Sync systems	Internal/External	
Card slots	2 slots: Analog RGB-Component card / SDI card / DV card	
Operating temperature	0 to 40 degrees (32 to 104 °F)	
Storage temperature	-20 to 60 degrees (-4 to 140 °F)	
Power requirements	NTSC	AC100 to 120 V, 50/60 Hz
	PAL	AC220 to 240 V, 50/60 Hz
Power consumption	9 W (without optional cards)	
Dimensions(WxHxD)	8 3/8 x 3 1/2 x 9 1/4 inches (212 x 88 x 233 mm)	
Weight	5 lb 15 oz (2.7 kg)	
Supplied accessories	AC power cable (1), Terminal connector (1), RS-232C cable (3 m, 8-pin Mini DIN) (1), Operating instructions (1)	

RM-BR300 Remote Control Unit

Camera control interface	RS-232C (VISCA protocol) / RS-422 (VISCA protocol)	
External control	Contact closure	
Power requirement	DC 10.8 to 13.2 V	
Power consumption	2.4 W	
Dimensions (WxHxD)	15 1/2 x 7 3/8 x 5 3/4 inches (391.3 x 185 x 145.9 mm)	
Weight	2 lb 1 oz (950 g)	
Supplied accessories	AC adaptor (1), AC power cable (1), RS-232C cable (3 m, 8-pin Mini Din) (1), Terminal connector(2), Operating instructions (1)	

BRC-300 Pan/Tilt Range

PAN RANGE

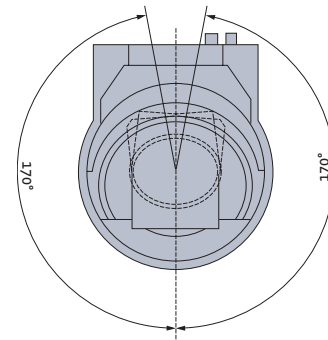

TILT RANGE

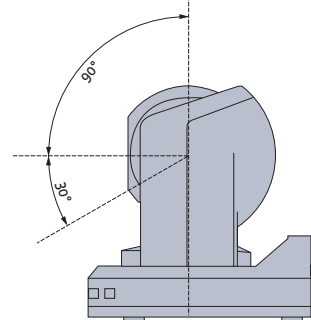

SONY

Sony Electronics Inc.
1 Sony Drive
Park Ridge, NJ 07656
www.sony.com/BRC300

V-2220-B
MK10091V2

©2005 Sony Corporation. All rights reserved.
Reproduction in whole or in part without written permission is prohibited.
Design, features, and specifications are subject to change without notice.
All non-metric weights and measurements are approximate.

Some images in this catalog are simulated.

Sony, Advanced HAD, VISCA, and Remote Commander are trademarks of Sony Corporation.
i.LINK is a Sony trademark used only to designate that a product is equipped with an IEEE 1394
connector. All products with an i.LINK connector may not communicate with each other. Please
refer to the documentation that comes with any device having an i.LINK connector for
information on compatibility, operating conditions, and proper connection.

Printed in USA (3/06)