

**HITACHI**  
Inspire the Next

# VK-S654<sub>(NTSC)</sub>/VK-S654E<sub>(PAL)</sub>

*Wide-Dynamic High-Sensitivity Color Zoom Camera*

- **Industry first compact X35 Optical Power Zoom Lens**
- **Electronic Image Stabilizer (EIS)**
- **Progressive recording direct to DVR**
- **High-sensitivity F1.4 lens, 0.5lx interlaced**
- **Wide-Dynamic Range (WDR)**
- **Day/night switching**
- **Lead-free**

Lead-free



x35  
OPTICAL  
ZOOM

EIS  
Electronic  
Image Stabilizer

PRD  
Progressive  
Recording Direct

WIDE  
DYNAMIC RANGE  
PROGRESSIVE SCAN

DIGITAL

MOTION

TD

PRIVACY  
ZONE

# VK-S654/S654E: Wide Dynamic Range Color Zoom Cameras with New Progressive Recording, Electronic Image Stabilizer, High-sensitivity F1.4 lens and Day/night switching

The Hitachi VK-S654/S654E is a lead-free compact chassis-type camera designed for surveillance of various sites under a wide range of light conditions. Even high-contrast scenes can be captured without glare or loss of detail thanks to the Wide Dynamic Range design.

## Industry First Compact x35 Optical Zoom Lens

A reliable built-in x35 optical power zoom lens allows the user to monitor a scene from any angle. Combined with x12 digital zoom, the total zoom ratio is x420. Maximum digital zoom is x2 when EIS is activated.

## Progressive Recording Direct to HDD

Record high quality video directly to your hard disk. Say goodbye to grainy images and troublesome lines with progressive recording. Use this new function for clearer, better quality video.

## Electronic Image Stabilizer

Hitachi's EIS function allows for the ultimate video experience. By automatically eliminating blurry, jumpy images the VK-S654R/S654ER can be mounted in a vehicle to give crisp, easy-to-view images.

## Wide Dynamic Range (WDR)

Hitachi's Wide Dynamic Range Technology uses two shutter speeds in alternative video fields and combines two fields into one progressive scan frame. The highly sensitive F1.4 lens allows detailed capture of images even in a mixture of over-bright and dark scenes.

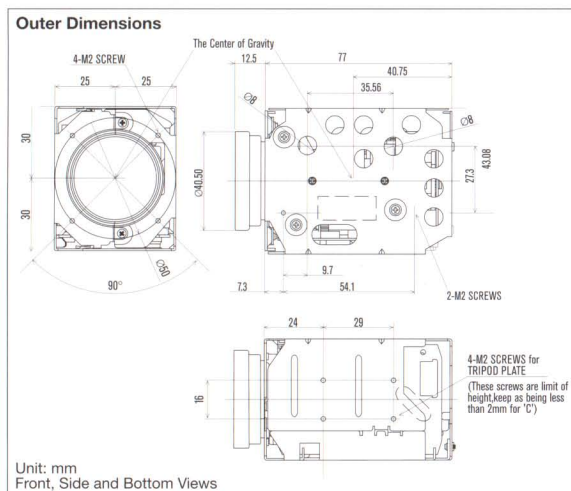

## VK-S654/VK-S654E Specifications

Signal Format	VK-S654 (NTSC) Lead free / S654E (PAL) Lead free
<b>CCD Image Sensor</b> Total Pixels Effective Pixels Practical Pixels Progressive Scan	Image Size 4.5mm Dia. (1/4-inch) 410k (811 x 508) (NTSC) / 470k (795 x 596) (PAL) 380k (768 x 494) (NTSC) / 440k (752 x 582) (PAL) 380k (768 x 494) (NTSC) / 440k (752 x 582) (PAL) Yes
<b>Lens Optical</b> Zoom Magnification Practical f-value Practical Horiz. Angle F-value Zoom Speed(Manual) (In Preset : Trace / No-)	35X (f=3.4 - 119mm) 3.4 - 119mm 55.8°(w) - 1.7°(t) F1.4(w)* - F4.2(t) 4.6s*/6.6s (soft) 3.2s/2.0s (soft)
<b>Focus</b> Auto Manual (Far/Near) Focal Range	VAF Possible(soft) infinity - 1m(t) - 0.01m(w)* (soft)
<b>IR Cut Filter Removable</b> Auto  Manual (ON/OFF)	Pro. AER+* (OFF - ON - 1/4* - 1/4k) (NTSC) Pro. AER+* (OFF - ON - 1/3* - 1/4k) (PAL) Provided (soft)
<b>Durability</b> Zoom/Focus/Iris IR Removable	500k cycles 50k cycles
<b>DSP Functions</b> Digital Slow Shutter Frame Output Wide Dynamic Range Image Stabilizer Image Reverse Mirror** Image Freeze** B&W Privacy Masking*** Fixed Privacy Masking Title display Motion Detect*** Various customizable settings Dynamic Spot cancel	DSP-7 Yes (SDRAM I/F) w/o WDR OFF*/ON(soft) OFF*/ON (Auto* [offset]/Manual) (soft) YES (Digital Zoom max.1.3x) OFF*/ON (soft) w/ WDR OFF*/ON (soft) w/ WDR OFF*/ON* (soft) OFF*/ON(soft) OFF*/ON* [ 2zone 2-D*/ 8zone 3-D (4/1 screen)] (soft) OFF*/ON [ optional:12 x 24 units ] (soft) OFF*/ON [ 24 characters ] (soft) OFF*/ON (soft) YES [ preset store (max. 111), WB tuning ] YES (w/o AGC 0dB)
<b>Digital Zoom</b> Zoom Magnification	OFF*/ON ( [ soft : max. 12X ] )
<b>Electrical Shutter</b> Auto Auto (+DS Shutter)  Manual  Manual (Sensitivity)	Pro. AE (1/60 - 1/4ks) (NTSC) / (1/50 - 1/4ks) (PAL) Pro. AE+*(1/2 - 1/4* - 1/4ks : Seamless)(NTSC) Pro. AE+*(1/1.5 - 1/3* - 1/4ks : Seamless)(PAL) Shutter priority 1/2 - 1/30ks : soft Exposure priority F1.4 - F32 : soft AGC priority 0 - 30dB : soft 32X, 16X, 8X, 4X, 2X (soft)
<b>Iris</b> BLC	Auto*/(offset: soft) OFF*/ON (soft)
<b>White Balance</b>	Auto*/(manu: soft)
<b>Horizontal Resolution</b> Normal (1/60s)(NTSC) / (1/50s)(PAL)	typ.540 .min.520 TVL
<b>Luminance S/N Ratio</b>	More than 50 dB
<b>Min. Sensitivity Typical</b> IR-cut ON (1/60s)(NTSC) / (1/50s)(PAL) IR-cut ON (1/4s)(NTSC) / (1/3s)(PAL) IR-cut ON (1/2s)(NTSC) / (1/1.5s)(PAL) IR-cut OFF (1/4s)(NTSC) / (1/3s)(PAL) w/ IR illuminator (Option)	0.5 lx : Interlace/1lx : Progressive* 0.05 lx : Interlace/0.1 lx : Progressive* 0.025 lx : Interlace/0.05 lx : Progressive* Approx. 0.01 lx (B/W*) : Progressive* (0.1 lx B/W*) : Progressive*
<b>In 3m</b> Condition	(F1.4 (w), 350mv)
<b>Sync System</b>	Internal/Line-Lock (60Hz) (NTSC) Internal/Line-Lock (50Hz) (PAL)
<b>Power</b> Supplied Voltage Supplied Current Max. Consumption max.	9-12V DC 290mA w/ WDR 380mA w/ WDR 2.6W (3.4W) w/ WDR
<b>Video Output</b>	VBS:1.0Vp-p. Y/C Output
<b>Dimension (W x H x D)</b>	50 x 60 x 89.5mm (w/ M-case)
<b>Weight</b>	240g (w/ M-case)
<b>No. of Connectors</b>	2 (9pin / 4pin : Y/ C Output)
<b>Operating Temp. (Recommend)</b>	0°C - 60°C (0°C - 40°C)

\* Default mode. WDR=Wide Dynamic Range. Design and specifications are subject to change without notice.

**HITACHI**  
Hitachi, Ltd. Tokyo Japan

**Hitachi, America, Ltd.**  
900 Hitachi Way, Chula Vista, CA 91914-3556  
Tel: 800-981-2588 Fax: 800-438-7098  
Tel: +1-619-591-5200 Fax: +1-619-591-5201  
www.hitachi.com

**Hitachi Europe Ltd.**  
Whitebrook Park, Lower Cookham Road, Maidenhead,  
Berkshire SL6 8YA

**Hitachi Home Electronics Asia (S) Pte. Ltd.**  
438A Alexandra Road #01-01/02/03,  
Alexandra Technopark, Singapore 119967  
Tel: +65-6536-2520 Fax: +65-6536-2521  
www.hitachimultimedia.com.sg

**Hitachi Sales Corporation of Taiwan**  
2nd F1., No. 65n Nanking E Rd.,  
Sec. 3 Taipei, 104 Taiwan  
Tel: +886-2-2512-5100 Fax: +886-2-2512-5110