

PRECISION MACHINE VISION LENS



VT4Z1450MXJ

1inch 14-50mm
6MP IR-Corrected

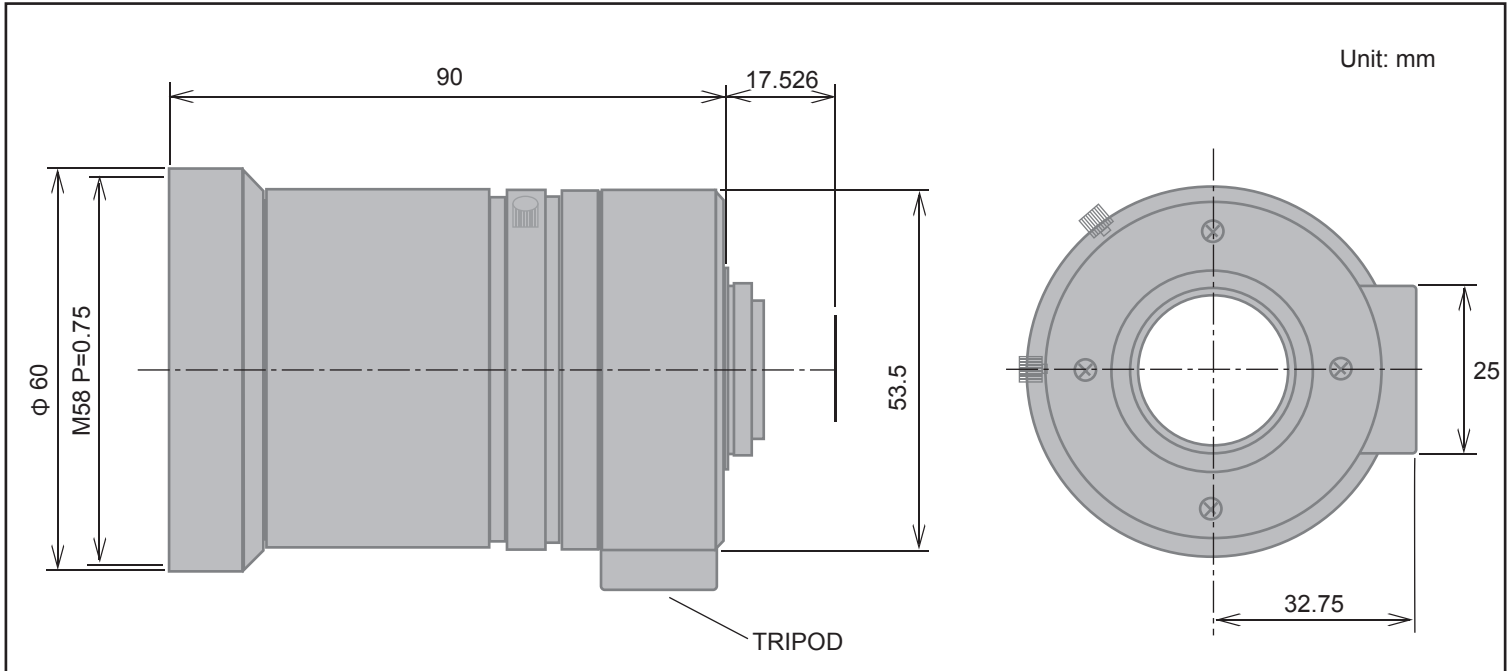

Image Format	1-inch
Focal Length	14-50 mm
Relative Aperture	F=1:2.6
Iris Range	2.6 to 16
Angular Field of View	f14mm: 50.5° x 38.0° f50mm: 14.5° x 11.1°
Resolution	6MP (Center:130lp/mm, Corner: 111lp/mm)
M.O.D.(Minimum Object Distance)	1.2m
Back Focal Length	13.995mm
Flange Back	17.526mm
Operation	Focus: Manual with lock screw Zoom: Manual with lock screw Iris: Manual with lock screw
Lens Mount	C-mount
Filter Screw	M58 P=0.75
Dimensions	Φ60.0x 90.0mm (max.)
Weight	395g
Operating Temperature	-10 to +50°C
Note	with Tripod