

BOBCAT

INTELLIGENT CAMERA SERIES

IGV-B1320

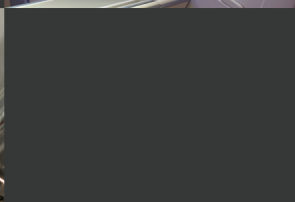
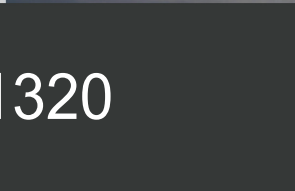

The IGV-B1320 is an advanced progressive scan, fully programmable CCD camera designed for imaging applications that require high quality images, powerful features and flexibility. The camera is small, light weight, and built around Kodak's KAI-01150 5.5 micron Interline Transfer CCD image sensor with a 1/2" optical format.

The IGV-B1320 provides an image resolution of 1320 x 736 and delivers up to 85 frames per second at full resolution. The camera's 14 bit internal data image processing engine is based on an industrial grade high-speed, high-density FPGA, enabling a broad standard feature set and easy implementation of demanding custom imaging solutions. The thermally optimized, mechanical and electrical design plus the extended operating temperature range (-40°C to +85°C), and high MTBF of 660,000 hrs @ 40C, make this GigE Vision camera a perfect fit for the most demanding industrial, medical, scientific and military applications. This camera is also available with the following interfaces: CoaXPress and Camera Link®.

Features

- 1320/1280 x 736/720
- Mono, color, or TRUESENSE 8, 10, 12 bit single or dual output (16 bit is single only)
- Normal and over-clock operation (68/85 fps)
- 10/100/1000 Gigabit Ethernet LAN (RJ-45)
- RS232 serial communication
- Analog and digital gain and offset control
- 1x, 2x, 3x, 4x, 8x horizontal and vertical binning
- Eight (8) independent horizontal and vertical AOIs
- Programmable horizontal and vertical resolution
- Programmable line time, frame time and speed
- Programmable external trigger
- Internal/External exposure control
- Standard, fast, frame accumulation, double and asynchronous triggering modes
- Automatic gain, exposure and iris control

- Automatic white balance
- Internal/External H and V sync input/output
- Left/right digital bit shift
- Test image with image superimposition
- Built in pulse generator
- Programmable I/O mapping
- Dynamic transfer function correction
- Dynamic black level correction
- Defective and hot pixel correction (static/dynamic)
- Temperature monitor
- Field upgradeable firmware
- Customer defined Look Up Table (LUT)
- Two dimensional Flat Field Correction (optional)
- Reverse image (H mirror)
- MTBF of 660,000 hrs. @ 40°C

APPLICATIONS

Aerial Mapping
Aerial Robots: Military, Police
Aerospace
Agriculture
Automation

Automotive
Biometrics
Broadcasting
Printed Circuit Board (PCB)
Electronics
Energy/Solar/Wind Power

Flat Panel Inspection
Food/Beverage
Homeland Security
Law Enforcement
Intelligent Traffic Systems (ITS)
Medical Devices/Imaging

Metrology
Microscopy
Military/Defense
Pharmaceuticals
Particle Image Velocimetry (PIV)
Radiology

Robotics
Scientific Apps
Surveillance
Semiconductors
Transportation
Textile/Apparel



TM

BOBCAT IGV-B1320 Specifications

Maximum Resolution	1320 x 736
Sensor Type	1/2" CCD KAI-01150
Pixel Size	5.50 μ m
Frame Rate	68/85 fps (normal/overclock)
Max Frame Rate	395 FPS
Minimum S/N ratio	60 db
Video Output	RJ45 CAT5e, CAT6
Output Format	Mono, color, or TRUESENSE 8, 10, 12 bit single or dual output (16 bit is single only)
Binning H & V	x1, x2, x3, x4, x8
Area of Interest	8 independent AOIs, 2 x 2 to 1320 x 736
Shutter Speed	1/250,000 to 1/68 sec (nom)
Long Integration	Up to 16 sec
Gamma Correction	G=1.0, G= 0.45, user upgradable LUT
Video Gain	36 dB range, 1024 steps, 0.0351 dB per step
Exposure and AGC	Manual, Auto, Programmable
Iris Control	Auto, Programmable
Strobe Output	Programmable position and duration
Image Overlay	Yes, Programmable

Data Corrections
Hardware Trigger

Software Trigger

Trigger Modes

Min. Illumination
Supply Input Range
Power Consumption
Size (W x H x L)
Weight
Lens Mount
Vibration, Shock
Environmental

Humidity
MTBF
Regulatory

DPC, HPC, LUT, FCC
LVTTTL or TTL via IN1/IN2, level, edge, pulse-width, programmable
Software internal, level, edge, pulse-width, programmable
Programmable, standard, double exposure, fast, frame accumulation, asynchronous
1 Lux, F/1.4
12 VDC, (10 V – 15 V)
4.5 W, 380 mA steady (Typ), 1.5 A inrush
46 x 46 x 74.5mm
229g
C mount
10G (20 - 200)Hz XYZ, 70G
Operation (-40° to +85°C),
Storage (-40° to +90°C)
10% to 90% non-condensing
660,000 hrs. @ 40°C
FCC 15 part A, CE, RoHS

Power and I/O Interface:



1	12V DC Return	7	OUT1 Signal
2	+12V DC	8	IN1 Signal
3	IRIS VCC	9	IN2 Signal
4	IRIS Video	10	IN1/2 Return
5	IRIS Return	11	Reserved
6	OUT1/2 Return	12	OUT2 Signal

Connector: Hirose HR 10A-10R-12PB(71)

Order Options:

IGV-B1320M-KCO	Monochrome GigE Vision Output
IGV-B1320C-KCO	Color GigE Vision Output
IGV-B1320T-KCO	TRUESENSE GigE Vision Output

For specific details and ordering information, consult the camera user's manual or contact IMPERX at sales@imperx.com.

Accessories:

PS12V04: Power Supply (sold separately)

Spectral Response

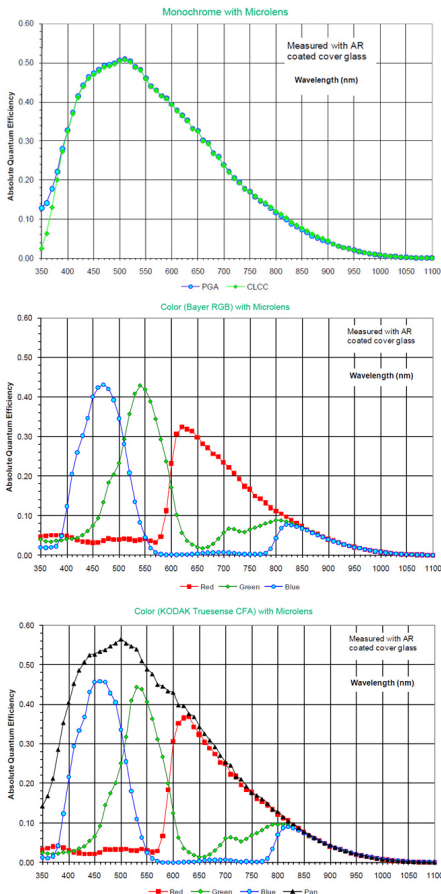

Software/Drivers/Interface

GigE Vision Protocol: 10/100/1000 Mb/s, 802.3, Ethernet V2.0, IPv4, IGMPv.2, UDP and ICMP, and GenICam

eBUS Drivers: Windows XP 32b, XP 64b, Vista 32b, Vista 64b, 7 32b, 7 64b. Linux: SuSE v10, RedHat 5 (Kernel 2.6)

Software: Pleora GEVPlayer, IMPERX GEV Player (includes Cam-Config GUI), Bobcat GEV Download Utility, Net Command

SDK: PureGEV GigE Vision SDK for Windows (Microsoft Visual C++, COM, .NET, C#, VB.NET, Borland C++Builder), PureGEV, GigE Vision SDK for Linux

Compatible with: Labview, Halcon, MIL, Common Vision BLOX, StreamPix, ActiveGigE, and others

Multicast capable

Mechanical Dimensions

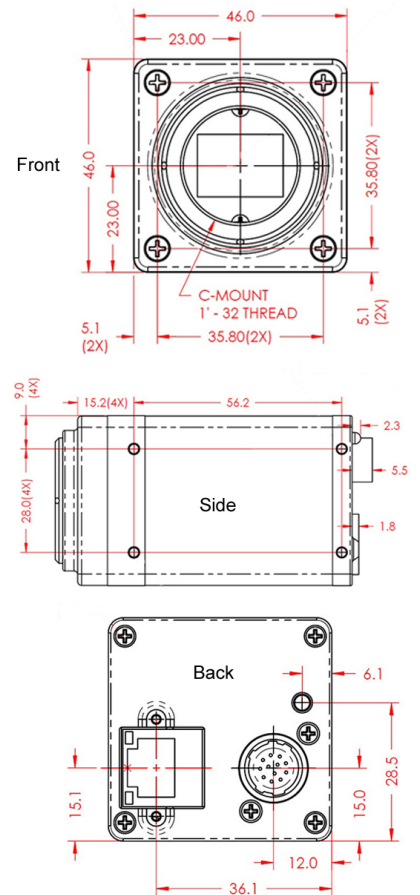

IMPERX | 6421 Congress Avenue | Boca Raton | FL 33487 | USA
 Phone: +1-561-989-0006 | 1-866-849-1662 | Fax: +1-561-989-0045
 www.imperx.com | sales@imperx.com

