

BMH-S308

2MP x30 AF 3G-SDI Box Camera

HD-SDI 



FEATURES

- 1/2" 2MP 60fps Panasonic CMOS sensor
- 1080p 60fps / 30fps, 720p 60fps
- 3G-SDI, HD-SDI, EX-SDI, TVI, CVBS, HDMI
- x30 Optical Zoom(4.3~129mm) & x32 Digital Zoom
- Real-time True WDR
- Digital Noise Reduction(2D+3D)
- Digital Slow Shutter
- Digital Image Stabilizer
- De-Fog, Live Defect correction, HLC(High Light Compensation)
- ACE(Advanced Contrast Enhancement)
- Privacy Mask, Motion Detection
- Protocol(VISCA, Pelco-D, Pelco-P)

DIMENSIONS

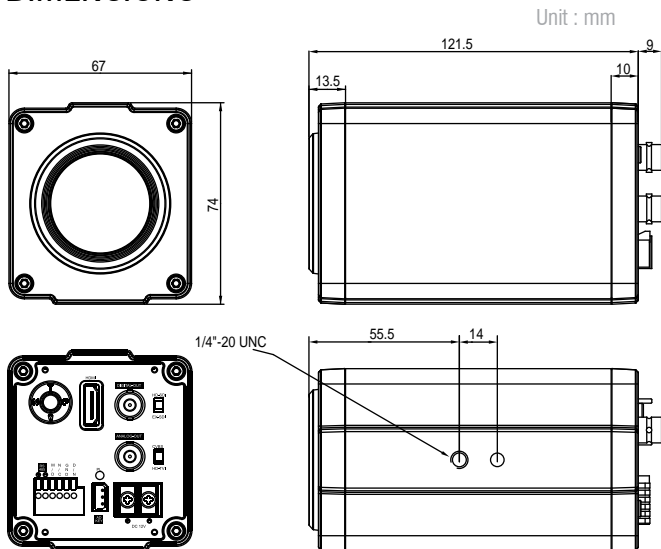

SPECIFICATIONS

BMH-S308		
Image sensor	Sensor Type	1/2" Sony CMOS
	Image Size	Diagonal 8.58 mm(Type 1/1.9)
	Effective Pixels	1945(H) x 1225(V) = 2.38M (pixel)
Resolution		Digital : 1080p/60(50)fps, 1080p/30(25)fps, 720p/60(50)fps, 720p/30(25)fps
Scanning System		Progressive
Min.Illumination		Color : 0.5Lux, BW : 0.1Lux
		Color DSS : 0.125 lux , BW DSS : 0.025 lux
Video Output		3G-SDI, HD-SDI, EX-SDI, TVI, CVBS, HDMI
S/N Ratio		More than 50dB(AGC off)
Lens	Lens Type	x30, Day & Night Zoom Lens
	Zoom Ratio	Optical x30 , Digital x32
	Focal Length	f = 4.3 mm ~ 129 mm
	Aperture Ratio	F1.6 (wide) ~ F4.7 (tele)
	Focus Distance	0.1 / 1.0 / 3.0 / 6.0 / 10.0 m
Function	Digital Zoom	Off / x2 ~ x32
	Exposure	Auto / Iris.P / Shut.P / Manual
	Gain Control	Off / On (Auto max.30dB)
	Shutter Speed	1/30(1/25) ~ 1/60,000
	Digital Shutter Speed	Off / x2 ~ x4
	Brightness	1 ~ 20 steps
	Output Format	1080p / 720p
	Frequency	60Hz / 50Hz
	WDR	Off / On
	BLC	Off / On
	HLC	Off / On
	Day & Night	Auto / Day / Night / Ext-in
	White Balance	Auto / One Push / Manual / Indoor / Outdoor
	DNR	Off / Auto / Low / Middle / High
	Privacy Mask	Off / 24 positions
	Motion Detection	Off / 3 positions
	Defog	Off / On
	Mirror	Off / H / V / H+V
	Sharpness	0 ~ 10
	Defect Detection	Off / On
CVBS Output	Off / On	
Communication	Protocol	Pelco -D / Pelco-P / VISCA
	Baud Rate	2400 / 4800 / 9600 / 19200 / 38400 / 57600 / 115200
Electrical	Power source	DC 12V ± 10%
	Power consumption	Max 500mA
General	Operating Temperature	-10℃ ~ +50℃
	Storage Temperature	-20℃ ~ +60℃
Weight		Approximately 0.57kg